

Mayor
CERÁMICA

Índice por paginación

Index by pagination

04.
Sobre Cerámica Mayor
About Cerámica Mayor

05.
Simbología
Symbology

06.
Lectura del catálogo
Reading the catalogue

08.
Colecciones
Collections

10.
Crosscut

26.
Veincut

34.
Savoy

46.
Stromboli

58.
Cupira

68.
Salem

78.
Coralina

90.
Lao

100.
Eterna

108.
Iconic

116.
Calacatta

122.
Cements

132.
Cotto

138.
Amazonia

148.
Tropic

156.
Bali

166.
Volcanic

167.
Gres porcelánico
espesorado de 20MM
20MM thick porcelain
stoneware

180.
Soluciones para
piscinas
Pool solutions

192.
Bordes, rejillas y
medias cañas para
piscinas
Edges, drain grates
and trims for
swimming pools

194.
Creta

196.
Samoa

198.
Maui

200.
Aruba

202.
Rejillas de drenaje
Drain grates

212.
Piezas de terminación
Trimss

218.
Colocación de pavimento
Laying of flooring

224.
Colocación de peldaños
Placement of steps

226.
Colocación de piezas
especiales para piscinas
Installation of special pieces
for swimming pools

228.
Instalación Sistema Block 25
Block 25 system installation

230.
Dimensiones de las piezas
Pieces dimensions

231.
Información técnica del
pavimento
Technical information of the
pavement

232.
Ventajas del gres porcelánico
Pocelain stoneware
advantages

233.
Información embalaje
Packing data

238.
Resumen colecciones
Collections overview

Índice por formato

Index by format

Estándar Standard

120x120CM
47.2"x47.2"

10.
Crosscut

68.
Salem

108.
Iconic

90x90CM
35.4"x35.4"

10.
Crosscut

34.
Savoy

68.
Salem

78.
Coralina

92.
Lao

132.
Cotto

20x120CM
7.8"x47.2"

138.
Amazonia

30x120CM
11.8"x47.2"

138.
Amazonia

60x120CM
23.6"x47.2"

10.
Crosscut

26.
Veincut

34.
Savoy

46.
Stromboli

58.
Cupira

68.
Salem

78.
Coralina

90.
Lao

100.
Eterna

108.
Iconic

116.
Calacatta

126.
Cements

75x75CM
29.5"x29.5"

42.
Stromboli

118.
Cements

37.5x75CM
14.7"x29.5"

10.
Crosscut

26.
Veincut

46.
Stromboli

58.
Cupira

126.
Cements

60x60CM
23.6"x23.6"

10.
Crosscut

46.
Stromboli

68.
Salem

78.
Coralina

30x60CM
11.8"x23.6"

148.
Tropic

156.
Bali

166.
Volcanic

Pavimento 20MM Pavement 20MM

90x90x2CM
35.4"x35.4"x0.78"

30.
Savoy

64.
Salem

60x120x2CM
23.6"x47.2"x0.78"

10.
Crosscut

46.
Stromboli

Pequeño formato Small format

14.7x14.7CM
5.7"x5.7"

54.
Cupira

144.
Tropic

152.
Bali

162.
Volcanic

**Somos tradición,
inconformismo, valentía.
We are tradition,
non-conformism, courage.**



Cerámica Mayor S.A. es una empresa líder en la fabricación de material extrusionado con una larga tradición en la producción de pavimentos y piezas especiales, tanto en acabado natural como esmaltado. La empresa fue fundada en el siglo pasado por D. Fernando Mayor Boluda y hoy en día es dirigida por los hermanos Mayor.

Desde sus inicios ha mantenido intactos sus valores, creencias y costumbres, transmitiéndolas de generación en generación y aplicándolas a todas y cada una de sus formas de expresión con inconformismo y valentía, partiendo de la base de materiales que nos aporta la naturaleza para transformarlos, con creatividad, en algo único. Siempre un paso más allá.

Cerámica Mayor S.A. is a leading company in the manufacture of extruded material with a long tradition in the production of pavements and special pieces, both in natural and glazed finish. The company was founded in the last century by D. Fernando Mayor Boluda and today it is directed by the Mayor brothers.

Since its inception, it has kept its values, beliefs and customs intact, transmitting them from generation to generation and applying them to each and every form of expression with non-conformism and courage, starting from the base of materials provided by nature to transform them, with creativity, into something unique. Always a step further.

Simbología

Symbology



Tamaño de la base
Tile size

60x120cm 23.6"x47.2"

Tamaño en centímetros
Size in centimetres

60x120cm 23.6"x47.2"

Tamaño en pulgadas
Size in inches



Piezas y bases de exterior Clase 3
Outdoor pieces and tiles Class 3



Piezas y bases de interior Clase 1
Indoor pieces and tiles Class 1



Piezas y bases de exterior R11
Outdoor pieces and tiles R11



Piezas y bases de interior R9
Indoor pieces and tiles R9



Bases rectificadas
Rectified tiles



Grosor de la base
Tile thickness

MONOBLOCK

Fabricado de una pieza, sin pegado
Made in one piece, not glued



Sistema con goma de amortiguación
Rubber cushioning system



Patente mundial de la pieza
Worldwide patent of the piece



Porcentaje de desbordamiento
Percentage of overflow



Esmaltado a 3 caras
Enamelled on 3 sides



Esmaltado superior
Top glaze



Antideslizante Clase 1
Non-slip Class 1



Antideslizante Clase 3
Non-slip Class 3



Grosor lateral peldaño
Step side thickness



Producto de fácil limpieza
Easy clean product



Larga vida
Long life



EN ISO 10545-13
GA / GLA / GHA



EN ISO 10545-12



EN 16165
R11 | Clase C



EN 16165
Clase 3

Lectura del catálogo

Reading the catalogue

01.
Nombre de la colección y el color
Collection and colour name

02.
Descripción de la colección
Collection description

03.
Formatos disponibles
Available formats

04.
Información embalaje
Packing data

05.
Colores recomendados para la junta
Recommended joint colours

06.
Piezas especiales
Special pieces

07.
Sistema de piscina
Pool system

08.
Colores disponibles de la pieza especial
Available colours of the special piece

09.
Posibilidades de colocación
Placement possibilities

10.
Características técnicas
Technical information



03

Formatos | Formats



Embalaje | Packing

Formato	grasas / caps	m ² / caps	kg / caps	m ² / pallet	kg / pallet	grasas / caps	m ² / pallet	kg / pallet
33x33x10mm 128x128	2	1,40m ²	21,45	64,28	1.040,40	2	1,40m ²	21,45
33x33x10mm 128x128	2	1,40m ²	21,45	64,28	1.040,40	2	1,40m ²	21,45
33x33x10mm 128x128	2	1,40m ²	21,45	64,28	1.040,40	2	1,40m ²	21,45
33x33x10mm 128x128	2	1,40m ²	21,45	64,28	1.040,40	2	1,40m ²	21,45
33x33x10mm 128x128	2	1,40m ²	21,45	64,28	1.040,40	2	1,40m ²	21,45
33x33x10mm 128x128	2	1,40m ²	21,45	64,28	1.040,40	2	1,40m ²	21,45
33x33x10mm 128x128	2	1,40m ²	21,45	64,28	1.040,40	2	1,40m ²	21,45
33x33x10mm 128x128	2	1,40m ²	21,45	64,28	1.040,40	2	1,40m ²	21,45
33x33x10mm 128x128	2	1,40m ²	21,45	64,28	1.040,40	2	1,40m ²	21,45
33x33x10mm 128x128	2	1,40m ²	21,45	64,28	1.040,40	2	1,40m ²	21,45

Colores junta recomendados | Recommended joint colours



04

05

Pedraños | Steps

Pedraña recta | Recte step



Pedraña recta topa | Recte step corner



06

07

Creta

Borde de piscina | Pool edge

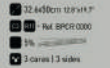

COLORES DISPONIBLES | AVAILABLE COLOURS



08

SOLUCIÓN CURVA | CURVED SOLUTION

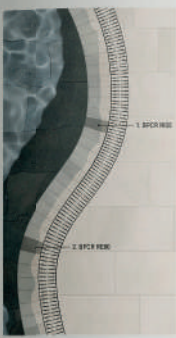

SOLUCIÓN ESQUINA | CORNER SOLUTION



BORDE CURVO CRETA
CRETA CURVED EDGE
1. BPCR R90
2. BPCR R90

PIEDR CURVO BORDE CRETA (CORNER)
CRETA CORNER PUNCH (CORNER)
1. BPCR R90 33.4x33cm 12.8x12.8"
2. BPCR R90 33.4x33cm 12.8x12.8"

INFORMACIÓN TÉCNICA | TECHNICAL INFORMATION



09

10

Colecciones

Collections



CROSSCUT PETRA

Crosscut

Colección
Collection

La colección Crosscut se inspira en el Travertino, piedra emblemática de la arquitectura clásica italiana, de tono beige claro. Su nombre, Crosscut, honra el corte transversal dado a los bloques originales de la piedra, alterando su apariencia habitual. Destaca por su textura porosa y sus cavidades naturales, otorgándole singularidad. Ofrece una amplia gama de matices e intensidades en su tonalidad. Disponible en dos tonos: Petra, su color natural, y Cloud, una variante azulada/grisácea.

The Crosscut collection is inspired by Travertine, an emblematic stone of classic Italian architecture, in a light beige tone. Its name, Crosscut, honours the transversal cut given to the original blocks of the stone, altering its usual appearance. It stands out for its porous texture and natural cavities, giving it uniqueness. It offers a wide range of nuances and intensities in its tonality. Available in two shades: Petra, its natural colour, and Cloud, a bluish/greyish variant.

Crosscut Puro

Color | Colour



Crosscut Petra

Color | Colour



Crosscut Cloud

Color | Colour



Montaje de suelo | Floor simulation

Crosscut Puro



Crosscut Petra



Crosscut Cloud



Formatos | Formats

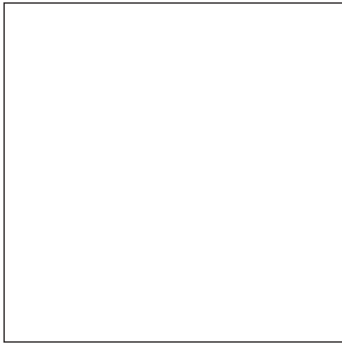

↖ ↗ 120x120cm 47.2"x47.2"

C3 R11 · C1 R9 ·

Crosscut Puro

Crosscut Petra

Crosscut Cloud

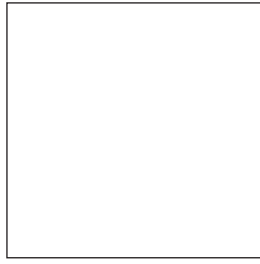

↖ ↗ 90x90cm 35.4"x35.4"

C3 R11 · C1 R9 ·

Crosscut Puro

Crosscut Petra

Crosscut Cloud

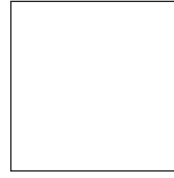

↖ ↗ 60x60cm 23.6"x23.6"

C3 R11 · C1 R9 ·

Crosscut Puro

Crosscut Petra

Crosscut Cloud

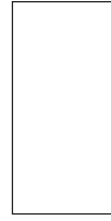

↖ ↗ 37.5x75cm 14.7"x29.5"

C3 R11 ·

Crosscut Puro

Crosscut Petra

Crosscut Cloud



↖ ↗ 60x120cm 23.6"x47.2"

C3 R11 · C1 R9 ·

Crosscut Puro

Crosscut Petra

Crosscut Cloud



↖ ↗ 60x120cm 23.6"x47.2"

↕ 20MM 0.78"

C3 R11 ·

Crosscut Puro

Crosscut Petra

Crosscut Cloud

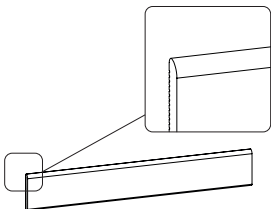

Rodapié
Skirting board

↖ ↗ 9x60cm 3.5"x23.6"

Coated Top

Crosscut Puro

Crosscut Petra

Crosscut Cloud

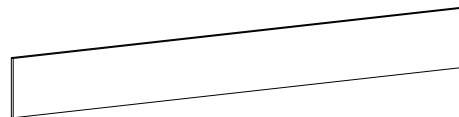

Tabica
Riser

↖ ↗ 14.5x120cm 3.5"x47.2"

Crosscut Puro

Crosscut Petra

Crosscut Cloud

Embalaje | Packing

Formatos Formats	piezas / caja pieces / box	m ² / caja sqm / box	kg / caja kg / box	m ² / palet sqm / pallet	tamaño palet pallet size
120x120 ^R cm 47.2"x47.2"	4	1,4400	31,00	57,60	125x125x69cm
90x90 ^R cm 35.4"x35.4"	2	1,6200	32,50	48,60	106x95x74cm
60x60 ^R cm 23.6"x23.6"	4	1,4400	27,00	46,08	120x80x74cm
37.5x75 ^R cm 14.7"x29.5"	1	1,1250	23,50	61,87	120x80x89cm
60x120 ^R cm 23.6"x47.2"		1,4400	31,65	46,08	120x84x74cm
60x120 ^R 2CM 23.6"x47.2"x0.78"	2	0,7200	34,37	19,44	120x84x74cm
9x60cm 3.5"x23.6"	1	-	15,36	-	110x95x96cm
Rodapié Skirting board	10				
14.5x120cm 3.5"x47.2"		-	22,20	-	125x110x90cm
Tabica Riser	6				

Colores junta recomendados | Recommended joint colours



Crosscut Puro

Mapei 100 Blanco
Kerakoll 02 Gris Luz
Litokol White 2
SikaCeram Blanco



Crosscut Petra

Mapei 130 Jasmine
Kerakoll 31 Beige Dakar
Litokol Ivory 2
SikaCeram Arena



Crosscut Cloud

Mapei 111 Silver Grey
Kerakoll 03 Gris Perla
Litokol Silver 1
SikaCeram Perla

Peldaños | Steps

Peldaño recto | Recto step



↖ ↗ 32.6x120cm 12.8"x47.2"

C3 R11 · C1 R9

■ Crosscut Puro

■ Crosscut Petra

■ Crosscut Cloud

Peldaño recto tapa | Recto step corner



↖ ↗ 32.6x120cm 12.8"x47.2"

C3 R11 · C1 R9

■ Crosscut Puro

■ Crosscut Petra

■ Crosscut Cloud

Peldaño completo | Full step



↖ ↗ 32.6x120cm 12.8"x47.2"

C3 R11 · 💧

■ Crosscut Puro

■ Crosscut Petra

■ Crosscut Cloud

Bordes de piscina | Pool edges

Borde Creta | Creta edge



↗ ↙ 32.6x50cm 12.8"x19.7"

C3 R11 · 🚰

🟫 Crosscut Puro

🟪 Crosscut Petra

🟩 Crosscut Cloud

Borde Maui | Maui edge



↗ ↙ 32.6x50cm 12.8"x19.7"

C3 R11 · 🚰

🟫 Crosscut Puro

🟪 Crosscut Petra

🟩 Crosscut Cloud

Borde Aruba | Aruba edge



↗ ↙ 24,6x50cm 9,6"x19.7"

C3 R11

🟫 Crosscut Puro

🟪 Crosscut Petra

🟩 Crosscut Cloud

Borde Samoa | Samoa edge



↗ ↙ 50x120cm 19.7"x47.6"

C3 R11 · 🚰

🟫 Crosscut Puro

🟪 Crosscut Petra

🟩 Crosscut Cloud

Rejillas de drenaje | Drain grates

Rejilla de drenaje RJ20 | Drain grate RJ20



- ↗ 19.3x50cm 7.6"x19.7" Desagüe | Drain: >11m³/hora
- C3 R11 · 🏠 🌐 Goma para rejilla 9134 incluida
Grate rubber 9134 included
- 🟫 Crosscut Puro
- 🟫 Crosscut Petra
- 🟫 Crosscut Cloud

Rejilla de drenaje RJ20 FLEX | Drain grate RJ20 FLEX



- ↗ 19.3x50cm 7.6"x19.7" Desagüe | Drain: >30m³/hora
- C3 R11 · 🏠 🌐 Goma para rejilla 9134 incluida
Grate rubber 9134 included
- 🟫 Crosscut Puro
- 🟫 Crosscut Petra
- 🟫 Crosscut Cloud

Rejilla de drenaje RJ25 | Drain grate RJ25



- ↗ 24,5x50cm 9,6"x19,7" Desagüe | Drain: >13m³/hora
- C3 R11 · 🏠 🌐 Goma para rejilla 9134 incluida
Grate rubber 9134 included
- 🟫 Crosscut Puro
- 🟫 Crosscut Petra
- 🟫 Crosscut Cloud

Rejilla de drenaje RJ25 FLEX | Drain grate RJ25 FLEX



- ↗ 24,5x50cm 9,6"x19,7" Desagüe | Drain: >30m³/hora
- C3 R11 · 🏠 🌐 Goma para rejilla 9134 incluida
Grate rubber 9134 included

Rejilla de drenaje RJ25 INV | Drain grate RJ25 INV



- ↗ 24,5x50cm 9,6"x19,7" Desagüe | Drain: >8m³/hora
- C3 R11 · 🏠 🌐 🚰 Goma para rejilla 12719 incluida
Grate rubber 12719 included
- 🟫 Crosscut Puro
- 🟫 Crosscut Petra
- 🟫 Crosscut Cloud

Goma para rejilla 9710 | Grate rubber 9710



Goma para rejilla 9134 | Grate rubber 9134



Goma para rejilla 12719 | Grate rubber 12719



Piezas de terminación | Trims

Media caña exterior
Outer trims



- ↗ 4.5x50cm 1.8"x19.7"
C3 R11 • Ref. MDCA E000
 Crosscut Puro
 Crosscut Petra
 Crosscut Cloud

Escocia cantonera exterior
Scotch external corner



- ↗ 4.5x4.5cm 1.8"x1.8"
C3 R11 • Ref. MDCA EE00
 Crosscut Puro
 Crosscut Petra
 Crosscut Cloud

Esquina cantonera exterior
Outer angle corner



- ↗ 6.5x6.5cm 2.6"x2.6"
C3 R11 • Ref. MDCA AE00
 Crosscut Puro
 Crosscut Petra
 Crosscut Cloud

Media caña interior
Inner trims



- ↗ 5.5x50cm 2.2"x19.7"
C3 R11 • Ref. MDCA I000
 Crosscut Puro
 Crosscut Petra
 Crosscut Cloud

Escocia cantonera interior
Scotch inner corner



- ↗ 5.5x5.5cm 2.2"x2.2"
C3 R11 • Ref. MDCA EI00
 Crosscut Puro
 Crosscut Petra
 Crosscut Cloud

Esquina cantonera interior
Inner angle corner



- ↗ 6.5x6.5cm 2.6"x2.6"
C3 R11 • Ref. MDCA AI00
 Crosscut Puro
 Crosscut Petra
 Crosscut Cloud

Cantonera transición exterior
External transition corner



- ↗ 4.5x25cm 1.8"x9.8"
C3 R11 • Ref. MDCA CE00
 Crosscut Puro
 Crosscut Petra
 Crosscut Cloud

Cantonera transición interior
Inner transition corner

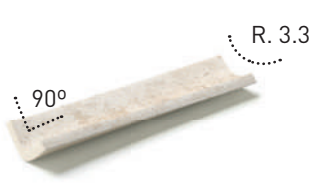

- ↗ 5.5x25cm 2.2"x9.8"
C3 R11 • Ref. MDCA CI00
 Crosscut Puro
 Crosscut Petra
 Crosscut Cloud

*Información detallada sobre las piezas de terminación en las páginas 212 y 213.

*Detailed information about trims pieces in pages 212 and 213.



VEINCUT ARENA

Veincut

Colección
Collection

Inspirada en la majestuosidad natural de la roca travertino, nuestra colección celebra el arte de la naturaleza y el ingenio humano. Formada en depósitos de aguas termales, ríos y manantiales ricos en carbonato de calcio, esta piedra icónica se distingue por sus vetas lineales y su textura única, testimonio de miles de años de historia geológica.

Cada pieza de la colección Veincut, ha sido diseñada y elaborada con una meticulosa atención al detalle. Nuestro equipo de diseño selecciona cuidadosamente los mejores bloques de travertino para garantizar una calidad excepcional. A través del exclusivo corte Vein Cut, las vetas longitudinales se resaltan de manera precisa, logrando un diseño fluido y uniforme que aporta movimiento y sofisticación.

El proceso de acabado combina tecnología de vanguardia con técnicas artesanales para preservar las características naturales de la piedra original, como su superficie porosa y las pequeñas cavidades que le otorgan su encanto único. Pero con las ventajas que conlleva estar realizado con gres porcelánico. Disponible en los tonos beige, crema, dorado y gris para adaptarse al estilo decorativo.

Inspired by the natural majesty of travertine rock, our collection celebrates the art of nature and human ingenuity. Formed in calcium carbonate-rich hot, rivers and springs, this iconic stone is distinguished by its linear veins and unique texture, a testament to thousands of years of geological history.

Each piece in the Veincut collection has been designed and crafted with meticulous attention to detail. Our design team carefully selects the finest travertine blocks to ensure exceptional quality. Through the exclusive Vein Cut, the longitudinal veins are precisely highlighted, achieving a fluid and uniform design that brings movement and sophistication.

The finishing process combines state-of-the-art technology with artisanal techniques to preserve the natural characteristics of the original stone, such as its porous surface and the small cavities that give it its unique charm. But with the advantages of being made of porcelain stoneware. Available in beige, cream, gold and grey tones to suit the decorative style.

Veincut Arena

Color | Colour



Veincut Sahara

Color | Colour



Veincut Basalt

Color | Colour



Montaje de suelo | Floor simulation

Veincut Arena



Veincut Sahara



Veincut Basalt



Formatos | Formats

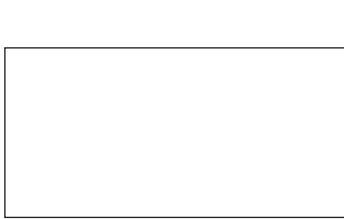

↙ ↘ 60x120cm 23.6"x47.2"

C3 R11 · C1 R9 ·

Veincut Arena

Veincut Sahara

Veincut Basalt



↙ ↘ 37.5x75cm 14.7"x29.5"

C3 R11 · C1 R9 ·

Veincut Arena

Veincut Sahara

Veincut Basalt

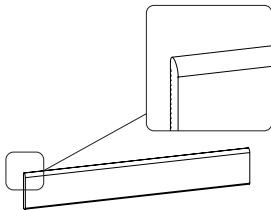

Rodapié
Skirting board

↙ ↘ 9x60cm 3.5"x23.6"

Coated Top

Veincut Arena

Veincut Sahara

Veincut Basalt

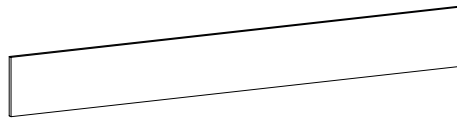

Tabica
Riser

↙ ↘ 14.5x120cm 3.5"x47.2"

Veincut Arena

Veincut Sahara

Veincut Basalt

Embalaje | Packing

Formatos Formats	piezas / caja pieces / box	m ² / caja sqm / box	kg / caja kg / box	m ² / palet sqm / pallet	tamaño palet pallet size
60x120 ^R cm 23.6"x47.2"	2	1,4400	31,65	46,08	120x84x74cm
37,5x75 ^R cm 14.7"x29.5"	4	1,1250	23,50	61,87	120x80x89cm

Colores junta recomendados | Recommended joint colours

Veincut Arena
Mapei 100 Blanco
Kerakoll Fugabella 43
Litokol Ivory 2
SikaCeram Beige

Veincut Sahara
Mapei 132 Baige 2000
Kerakoll Fugabella 39
Litokol Beige 2
SikaCeram Teca

Veincut Basalt
Mapei 110 Manhattan 2000
Kerakoll Fugabella 44
Litokol Grey 1
SikaCeram Ceniza

Peldaños | Steps

Peldaño recto | Recto step

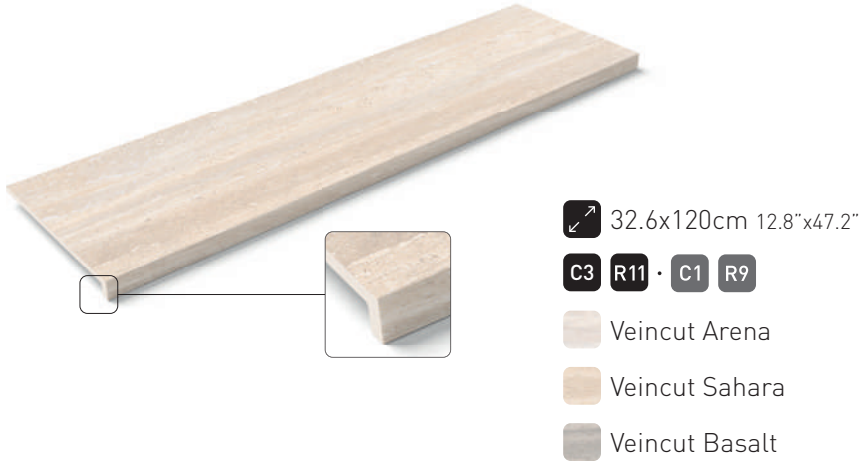

Peldaño recto tapa | Recto step corner

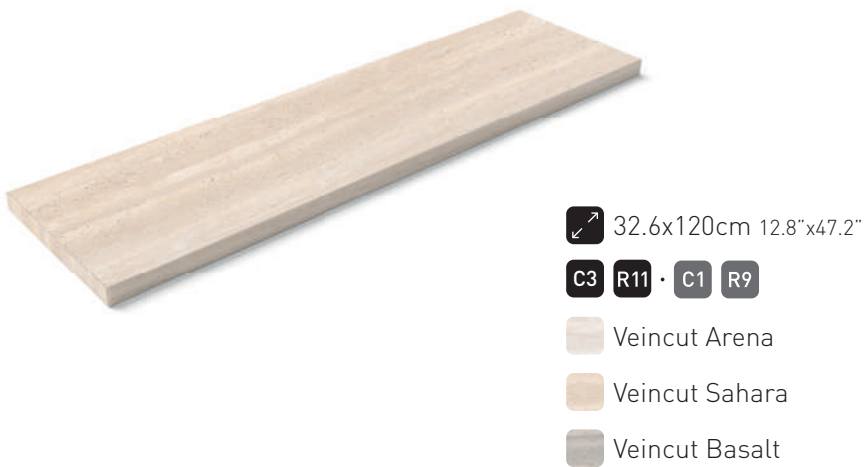

Bordes de piscina | Pool edges

Borde Creta | Creta edge



↗ ↙ 32.6x50cm 12.8"x19.7"

C3 R11 · 🚰

Veincut Arena

Veincut Sahara

Veincut Basalt

Borde Maui | Maui edge



↗ ↙ 32.6x50cm 12.8"x19.7"

C3 R11 · 🚰

Veincut Arena

Veincut Sahara

Veincut Basalt

Rejillas de drenaje | Drain grates

Rejilla de drenaje RJ25 FLEX | Drain grate RJ25 FLEX



↗ ↙ 24,5x50cm 9,6"x19.7"

Desagüe | Drain: >30m³/hora



Goma para rejilla 9134 incluida
Grate rubber 9134 included

Veincut Arena

Veincut Sahara

Veincut Basalt

Goma para rejilla 9710 | Grate rubber 9134



Rejilla de drenaje RJ25 INV | Drain grate RJ25 INV



↗ ↙ 24,5x50cm 9,6"x19.7"

Desagüe | Drain: >8m³/hora



Goma para rejilla 12719 incluida
Grate rubber 12719 included

Veincut Arena

Veincut Sahara

Veincut Basalt

Goma para rejilla 12719 | Grate rubber 12719



Piezas de terminación | Trims





Media caña exterior
Outer trims



-  4.5x50cm 1.8"x19.7"
- C3 R11** · Ref. MDCA E000
-  Veincut Arena
-  Veincut Sahara
-  Veincut Basalt





Escocia cantonera exterior
Scotch external corner



-  4.5x4.5cm 1.8"x1.8"
- C3 R11** · Ref. MDCA EE00
-  Veincut Arena
-  Veincut Sahara
-  Veincut Basalt





Esquina cantonera exterior
Outer angle corner



-  6.5x6.5cm 2.6"x2.6"
- C3 R11** · Ref. MDCA AE00
-  Veincut Arena
-  Veincut Sahara
-  Veincut Basalt

Media caña interior
Inner trims



-  5.5x50cm 2.2"x19.7"
- C3 R11** · Ref. MDCA I000
-  Veincut Arena
-  Veincut Sahara
-  Veincut Basalt

Escocia cantonera interior
Scotch inner corner



-  5.5x5.5cm 2.2"x2.2"
- C3 R11** · Ref. MDCA EI00
-  Veincut Arena
-  Veincut Sahara
-  Veincut Basalt





Esquina cantonera interior
Inner angle corner

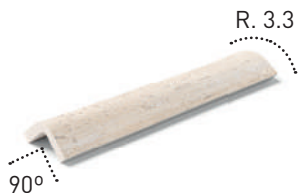

-  6.5x6.5cm 2.6"x2.6"
- C3 R11** · Ref. MDCA AI00
-  Veincut Arena
-  Veincut Sahara
-  Veincut Basalt





Cantonera transición exterior
External transition corner



-  4.5x25cm 1.8"x9.8"
- C3 R11** · Ref. MDCA CE00
-  Veincut Arena
-  Veincut Sahara
-  Veincut Basalt

Cantonera transición interior
Inner transition corner



-  5.5x25cm 2.2"x9.8"
- C3 R11** · Ref. MDCA CI00
-  Veincut Arena
-  Veincut Sahara
-  Veincut Basalt

*Información detallada sobre las piezas de terminación en las páginas 212 y 213.
*Detailed information about trims pieces in pages 212 and 213.



VEINCUT SAHARA



Savoy

Colección
Collection

Nuestra colección Savoy es una interpretación de la piedra Grigio Venato, nacida a los pies de los Alpes. Hemos seleccionado cuidadosamente cada bloque para garantizar su calidad y resaltar sus características vetas blancas que se entrecruzan armoniosamente con su rico fondo. Las sutiles transiciones entre zonas veteadas y fondo aporta dinamismo. Una propuesta de alta calidad que se adapta a la perfección a cualquier estilo decorativo.

Our Savoy collection is an interpretation of the Grigio Venato stone, born at the foot of the Alps. We have carefully selected each block to ensure its quality and to highlight its characteristic white veins that intertwine harmoniously with its rich background. The subtle transitions between the veined areas and the background bring dynamism. A high quality proposal that adapts perfectly to any decorative style.

Savoy Moon

Color | Colour



Savoy Desert

Color | Colour



Savoy Land

Color | Colour



Montaje de suelo | Floor simulation

Savoy Moon



Savoy Desert



Savoy Land



Formatos | Formats

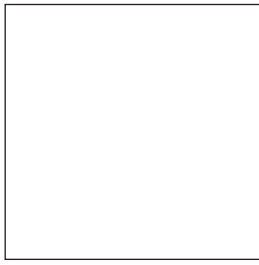

↙ ↘ 90x90cm 35.4"x35.4"

C3 R11 · C1 R9 ·

Savoy Moon

Savoy Desert

Savoy Land

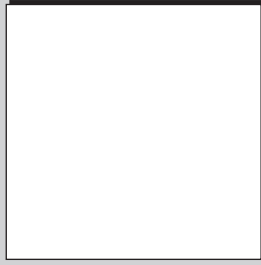

↙ ↘ 90x90cm 35.4"x35.4"

↕ 20MM 0.78"

C3 R11 ·

Savoy Moon

Savoy Desert

Savoy Land



↙ ↘ 60x120cm 23.6"x47.2"

C3 R11 · C1 R9 ·

Savoy Moon

Savoy Desert

Savoy Land

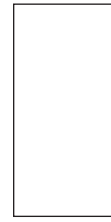

↙ ↘ 37.5x75cm 14.7"x29.5"

C3 R11 ·

Savoy Moon

Savoy Desert

Savoy Land

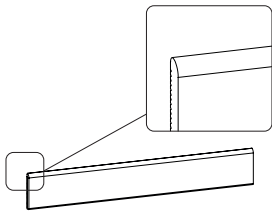

Rodapié
Skirting board

↙ ↘ 9x60cm 3.5"x23.6"

Coated Top

Savoy Moon

Savoy Desert

Savoy Land

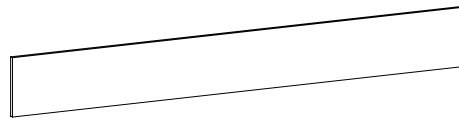

Tabica
Riser

↙ ↘ 14.5x120cm 3.5"x47.2"

Savoy Moon

Savoy Desert

Savoy Land

Embalaje | Packing

Formatos Formats	piezas / caja pieces / box	m ² / caja sqm / box	kg / caja kg / box	m ² / palet sqm / pallet	tamaño palet pallet size
90x90 ^R cm 35.4"x35.4"	2	1,6200	32,50	48,60	106x95x74cm
90x90 ^R 2CM 35.4"x35.4"x0.78"	1	0,8100	39,00	21,87	105x95x84cm
60x120 ^R cm 23.6"x47.2"	2	1,4400	31,65	46,08	120x84x74cm
37,5x75 ^R 14.7"x29.5"	4	1,1250	23,50	61,87	120x80x89cm
9x60cm 3.5"x23.6"	10	-	15,36	-	110x95x96cm
Rodapié Skirting board					
14.5x120cm 3.5"x47.2"	6	-	22,20	-	125x110x90cm
Tabica Riser					

Colores junta recomendados | Recommended joint colours

Savoy Moon

Mapei 100 White
Kerakoll 01 Blanco
Litokol White 1
SikaCeram Blanco

Savoy Desert

Mapei 130 Jasmine
Kerakoll 31 Beige Dakar
Litokol Ivory 3
SikaCeram Arena

Savoy Land

Mapei 112 Medium Grey
Kerakoll 04 Gris Hierro
Litokol Silver 2
SikaCeram Cemento

Peldaños | Steps

Peldaño recto | Recto step

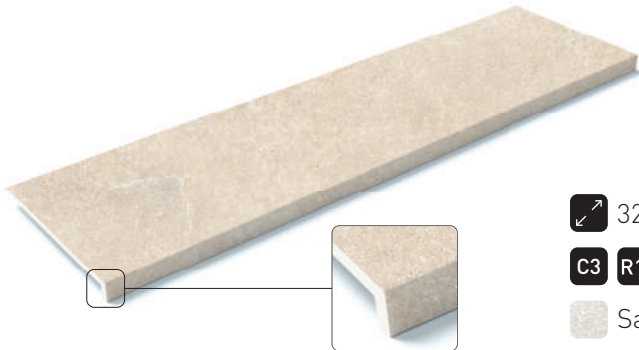

 32.6x120cm 12.8"x47.2"

C3 **R11** · **C1** **R9**

 Savoy Moon

 Savoy Desert

 Savoy Land

Peldaño recto tapa | Recto step corner



 32.6x120cm 12.8"x47.2"

C3 **R11** · **C1** **R9**

 Savoy Moon

 Savoy Desert

 Savoy Land

Bordes de piscina | Pool edges

Borde Creta | Creta edge



↗ 32.6x50cm 12.8"x19.7"

C3 R11 · 🚰

🟡 Savoy Moon

🟠 Savoy Desert

🟤 Savoy Land

Borde Maui | Maui edge



↗ 32.6x50cm 12.8"x19.7"

C3 R11 · 🚰

🟡 Savoy Moon

🟠 Savoy Desert

🟤 Savoy Land

Borde Samoa | Samoa edge



↗ 50x120cm 19.7"x47.6"

C3 R11 · 🚰

🟡 Savoy Moon

🟠 Savoy Desert

🟤 Savoy Land

Rejillas de drenaje | Drain grates

Rejilla de drenaje RJ25 | Drain grate RJ25





 24,5x50cm 9,6"x19.7" Desagüe | Drain: >13m³/hora



Goma para rejilla 9134 incluida
Grate rubber 9134 included

 Savoy Moon

 Savoy Desert

 Savoy Land

Goma para rejilla 9710 | Grate rubber 9710



Rejilla de drenaje RJ25 FLEX | Drain grate RJ25 FLEX



 24,5x50cm 9,6"x19.7" Desagüe | Drain: >30m³/hora



Goma para rejilla 9134 incluida
Grate rubber 9134 included

 Savoy Moon

 Savoy Desert

 Savoy Land

Goma para rejilla 9134 | Grate rubber 9134



Rejilla de drenaje RJ25 | Drain grate RJ25 INV



 24,5x50cm 9,6"x19.7" Desagüe | Drain: >8m³/hora



Goma para rejilla 12719 incluida
Grate rubber 12719 included

 Savoy Moon

 Savoy Desert

 Savoy Land





Goma para rejilla 12719 | Grate rubber 12719



Piezas de terminación | Trims





Media caña exterior
Outer trims



-  4.5x50cm 1.8"x19.7"
- C3 R11** • Ref. MDCA E000
-  Savoy Moon
-  Savoy Desert
-  Savoy Land





Escocia cantonera exterior
Scotch external corner



-  4.5x4.5cm 1.8"x1.8"
- C3 R11** • Ref. MDCA EE00
-  Savoy Moon
-  Savoy Desert
-  Savoy Land





Esquina cantonera exterior
Outer angle corner



-  6.5x6.5cm 2.6"x2.6"
- C3 R11** • Ref. MDCA AE00
-  Savoy Moon
-  Savoy Desert
-  Savoy Land





Media caña interior
Inner trims



-  5.5x50cm 2.2"x19.7"
- C3 R11** • Ref. MDCA I000
-  Savoy Moon
-  Savoy Desert
-  Savoy Land



Escocia cantonera interior
Scotch inner corner



-  5.5x5.5cm 2.2"x2.2"
- C3 R11** • Ref. MDCA EI00
-  Savoy Moon
-  Savoy Desert
-  Savoy Land





Esquina cantonera interior
Inner angle corner



-  6.5x6.5cm 2.6"x2.6"
- C3 R11** • Ref. MDCA AI00
-  Savoy Moon
-  Savoy Desert
-  Savoy Land





Cantonera transición exterior
External transition corner



-  4.5x25cm 1.8"x9.8"
- C3 R11** • Ref. MDCA CE00
-  Savoy Moon
-  Savoy Desert
-  Savoy Land

Cantonera transición interior
Inner transition corner



-  5.5x25cm 2.2"x9.8"
- C3 R11** • Ref. MDCA CI00
-  Savoy Moon
-  Savoy Desert
-  Savoy Land

*Información detallada sobre las piezas de terminación en las páginas 212 y 213.
*Detailed information about trims pieces in pages 212 and 213.



SAVOY MOON | TROPIC TURQUETA



STROMBOLI LIGHT

Stromboli

Colección
Collection

La colección Stromboli está inspirada en la piedra caliza. Su fondo regular se combina con incrustaciones de piedras más pequeñas agrupadas en mayores o menores conjuntos, simulando un flujo visual que agrega movimiento a la composición. Stromboli se presenta en tres tonos: Light, Cream y Silver. Una perfecta gama armoniosa que fusiona la sobriedad de la piedra caliza con la vitalidad que aportan las incrustaciones, logrando un resultado estéticamente cautivador.

The Stromboli collection is inspired by limestone. Its regular background is combined with inlays of smaller stones grouped in larger or smaller clusters, simulating a visual flow that adds movement to the composition. Stromboli comes in three shades: Light, Cream and Silver. A perfect harmonious range that fuses the sobriety of the limestone with the vitality provided by the inlays, achieving an aesthetically captivating result.

Stromboli Light

Color | Colour



Stromboli Cream

Color | Colour



Stromboli Silver

Color | Colour



Montaje de suelo | Floor simulation

Stromboli Light



Stromboli Cream



Stromboli Silver



Formatos | Formats

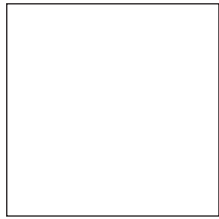

↗ 75x75cm 29.5"x29.5"

C3 R11 · C1 R9 · R

Stromboli Light

Stromboli Cream

Stromboli Silver

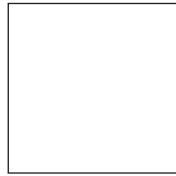

↗ 60x60cm 23.6"x23.6"

C3 R11 · R

Stromboli Light

Stromboli Cream

Stromboli Silver



↗ 37.5x75cm 14.7"x29.5"

C3 R11 · R

Stromboli Light

Stromboli Cream

Stromboli Silver



↗ 60x120cm 23.6"x47.2"

C3 R11 · C1 R9 · R

Stromboli Light

Stromboli Cream

Stromboli Silver



↗ 60x120cm 23.6"x47.2"

↕ 20MM 0.78"

C3 R11 · R

Stromboli Light

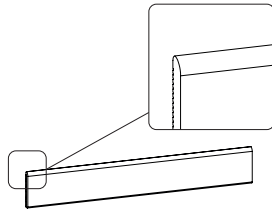

Rodapié
Skirting board

↗ 9x60cm 3.5"x23.6"

Coated Top

Stromboli Light

Stromboli Cream

Stromboli Silver

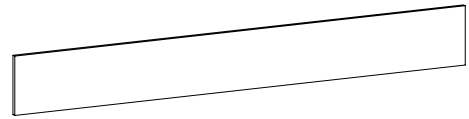

Tabica
Riser

↗ 14.5x120cm 3.5"x47.2"

Stromboli Light

Stromboli Cream

Stromboli Silver

Embalaje | Packing

Formatos Formats	piezas / caja pieces / box	m ² / caja sqm / box	kg / caja kg / box	m ² / palet sqm / pallet	tamaño palet pallet size
75x75 ^R cm 29.5"x29.5"	2	1,1250	23,50	54,00	120x80x90cm
60x60 ^R cm 23.6"x23.6"	4	1,4400	27,00	46,08	120x80x74cm
37.5x75 ^R cm 14.7"x29.5"	4	1,1250	23,50	61,87	120x80x89cm
60x120 ^R cm 23.6"x47.2"	2	1,4400	31,65	46,08	120x84x74cm
60x120 ^R 2CM 23.6"x47.2"x0.78"	1	0,7200	34,37	19,44	120x84x74cm
9x60cm 3.5"x23.6"	10	-	15,36	-	110x95x96cm
Rodapié Skirting board					
14.5x120cm 3.5"x47.2"	6	-	22,20	-	125x110x90cm
Tabica Riser					

Colores junta recomendados | Recommended joint colours

Stromboli Light
Mapei 100 White
Kerakoll 01 Blanco
Litokol White 1
SikaCeram Blanco

Stromboli Cream
Mapei 130 Jasmine
Kerakoll 31 Beige Dakar
Litokol Ivory 2
SikaCeram Arena

Stromboli Silver
Mapei 112 Medium Grey
Kerakoll 04 Gris Hierro
Litokol Silver 2
SikaCeram Cemento

Peldaños | Steps

Peldaño recto | Recto step



↗ 32.6x120cm 12.8"x47.2"

C3 R11 · C1 R9

Stromboli Light

Stromboli Cream

Stromboli Silver

Peldaño recto tapa | Recto step corner



↗ 32.6x120cm 12.8"x47.2"

C3 R11 · C1 R9

Stromboli Light

Stromboli Cream

Stromboli Silver

Peldaño completo | Full step



↗ 32.6x120cm 12.8"x47.2"

C3 R11 · 🔥

Stromboli Light

Stromboli Cream

Stromboli Silver

Bordes de piscina | Pool edges

Borde Creta | Creta edge



↗ 32.6x50cm 12.8"x19.7"

C3 R11 · 🚰

☐ Stromboli Light

☐ Stromboli Cream

☐ Stromboli Silver

Borde Maui | Maui edge



↗ 32.6x50cm 12.8"x19.7"

C3 R11 · 🚰

☐ Stromboli Light

☐ Stromboli Cream

☐ Stromboli Silver

Borde Samoa | Samoa edge



↗ 50x120cm 19.7"x47.6"

C3 R11 · 🚰

☐ Stromboli Light

☐ Stromboli Cream

Rejillas de drenaje | Drain grates

Rejilla de drenaje RJ20 | Drain grate RJ20



- ↗ 19.3x50cm 7.6"x19.7" Desagüe | Drain: >11m³/hora
 ↖ 19.3x50cm 7.6"x19.7" Desagüe | Drain: >30m³/hora
- C3** **R11** · 🏠 🌐
 Goma para rejilla 9134 incluida
 Grate rubber 9134 included
- ☐ Stromboli Light
 - ☐ Stromboli Cream
 - ☐ Stromboli Silver

Rejilla de drenaje RJ20 FLEX | Drain grate RJ20 FLEX



- ↗ 19.3x50cm 7.6"x19.7" Desagüe | Drain: >11m³/hora
 ↖ 19.3x50cm 7.6"x19.7" Desagüe | Drain: >30m³/hora
- C3** **R11** · 🏠 🌐
 Goma para rejilla 9134 incluida
 Grate rubber 9134 included
- ☐ Stromboli Light
 - ☐ Stromboli Cream
 - ☐ Stromboli Silver

Rejilla de drenaje RJ25 | Drain grate RJ25



- ↗ 24,5x50cm 9,6"x19,7" Desagüe | Drain: >13m³/hora
 ↖ 24,5x50cm 9,6"x19,7" Desagüe | Drain: >30m³/hora
- C3** **R11** · 🏠 🌐
 Goma para rejilla 9134 incluida
 Grate rubber 9134 included
- ☐ Stromboli Light
 - ☐ Stromboli Cream
 - ☐ Stromboli Silver

Rejilla de drenaje RJ25 FLEX | Drain grate RJ25 FLEX



- ↗ 24,5x50cm 9,6"x19,7" Desagüe | Drain: >13m³/hora
 ↖ 24,5x50cm 9,6"x19,7" Desagüe | Drain: >30m³/hora
- C3** **R11** · 🏠 🌐
 Goma para rejilla 9134 incluida
 Grate rubber 9134 included
- ☐ Stromboli Light
 - ☐ Stromboli Cream
 - ☐ Stromboli Silver

Rejilla de drenaje RJ25 INV | Drain grate RJ25 INV



- ↗ 24,5x50cm 9,6"x19,7" Desagüe | Drain: >8m³/hora
- C3** **R11** · 🏠 🌐 🌧️
 Goma para rejilla 12719 incluida
 Grate rubber 12719 included
- ☐ Stromboli Light
 - ☐ Stromboli Cream
 - ☐ Stromboli Silver

Goma para rejilla 9710 Grate rubber 9710



Goma para rejilla 9134 Grate rubber 9134







Goma para rejilla 12719 | Grate rubber 12719



Piezas de terminación | Trims





Media caña exterior
Outer trims



-  4.5x50cm 1.8"x19.7"
- C3 R11** · Ref. MDCA E000
-  Stromboli Light
-  Stromboli Cream
-  Stromboli Silver





Escocia cantonera exterior
Scotch external corner



-  4.5x4.5cm 1.8"x1.8"
- C3 R11** · Ref. MDCA EE00
-  Stromboli Light
-  Stromboli Cream
-  Stromboli Silver





Esquina cantonera exterior
Outer angle corner



-  6.5x6.5cm 2.6"x2.6"
- C3 R11** · Ref. MDCA AE00
-  Stromboli Light
-  Stromboli Cream
-  Stromboli Silver





Media caña interior
Inner trims



-  5.5x50cm 2.2"x19.7"
- C3 R11** · Ref. MDCA I000
-  Stromboli Light
-  Stromboli Cream
-  Stromboli Silver



Escocia cantonera interior
Scotch inner corner



-  5.5x5.5cm 2.2"x2.2"
- C3 R11** · Ref. MDCA EI00
-  Stromboli Light
-  Stromboli Cream
-  Stromboli Silver





Esquina cantonera interior
Inner angle corner



-  6.5x6.5cm 2.6"x2.6"
- C3 R11** · Ref. MDCA AI00
-  Stromboli Light
-  Stromboli Cream
-  Stromboli Silver





Cantonera transición exterior
External transition corner



-  4.5x25cm 1.8"x9.8"
- C3 R11** · Ref. MDCA CE00
-  Stromboli Light
-  Stromboli Cream
-  Stromboli Silver

Cantonera transición interior
Inner transition corner



-  5.5x25cm 2.2"x9.8"
- C3 R11** · Ref. MDCA CI00
-  Stromboli Light
-  Stromboli Cream
-  Stromboli Silver

*Información detallada sobre las piezas de terminación en las páginas 212 y 213.
*Detailed information about trims pieces in pages 212 and 213.



STROMBOLI LIGHT



CUPIRA MARENGO

Cupira

Colección
Collection

Con la colección Cupira, una pizarra natural procedente de América del Norte, obtenemos una amplia gama de tonalidades, haciendo que cada pieza sea única y atractiva. Cada laja es seleccionada para lograr un conjunto equilibrado de contrastes que dota a la colección de gran personalidad e impacto visual. El tono Multi resalta el carácter original de la piedra, mientras que los tonos Marengo y Hueso ofrecen una interpretación más sosegada sin perder su perfil salvaje. Su diversidad la hace adecuada para ambientes rústicos, mediterráneos y modernistas.

With the Cupira collection, a natural slate from North America, we obtain a wide range of shades, making each piece unique and attractive. Each slab is selected to achieve a balanced set of contrasts that gives the collection great personality and visual impact. The Multi tone highlights the original character of the stone, while the Marengo and Hueso tones offer a more sedate interpretation without losing its wild profile. Its diversity makes it suitable for rustic, Mediterranean and modernist environments.

Cupira Hueso

Color | Colour



Cupira Marengo

Color | Colour



Cupira Multi

Color | Colour



Montaje de suelo | Floor simulation

Cupira Hueso



Cupira Marengo

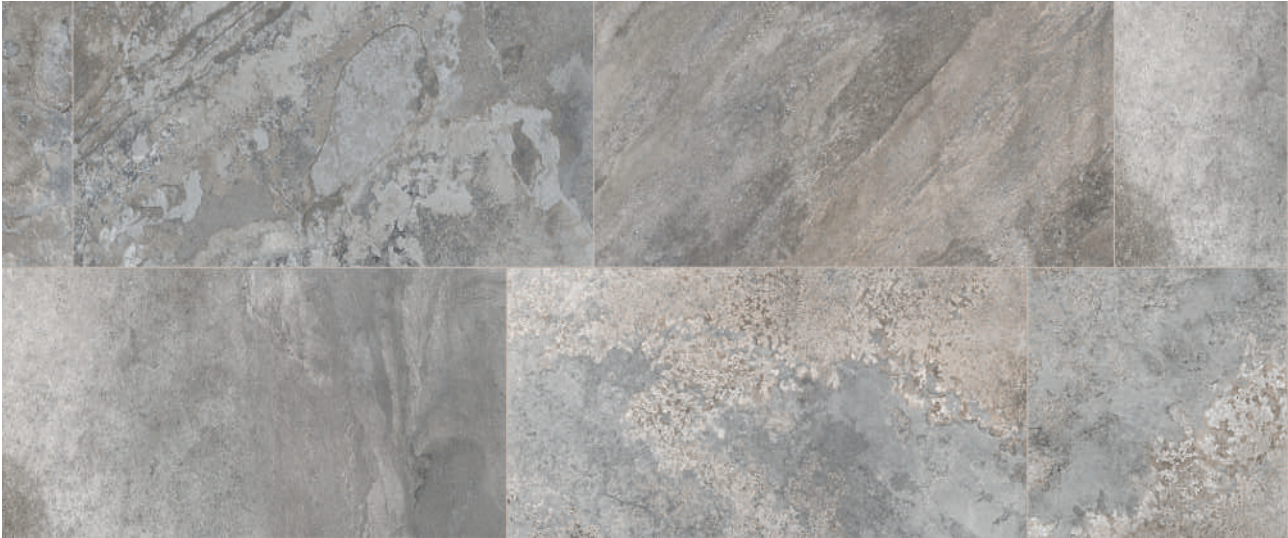

Cupira Multi

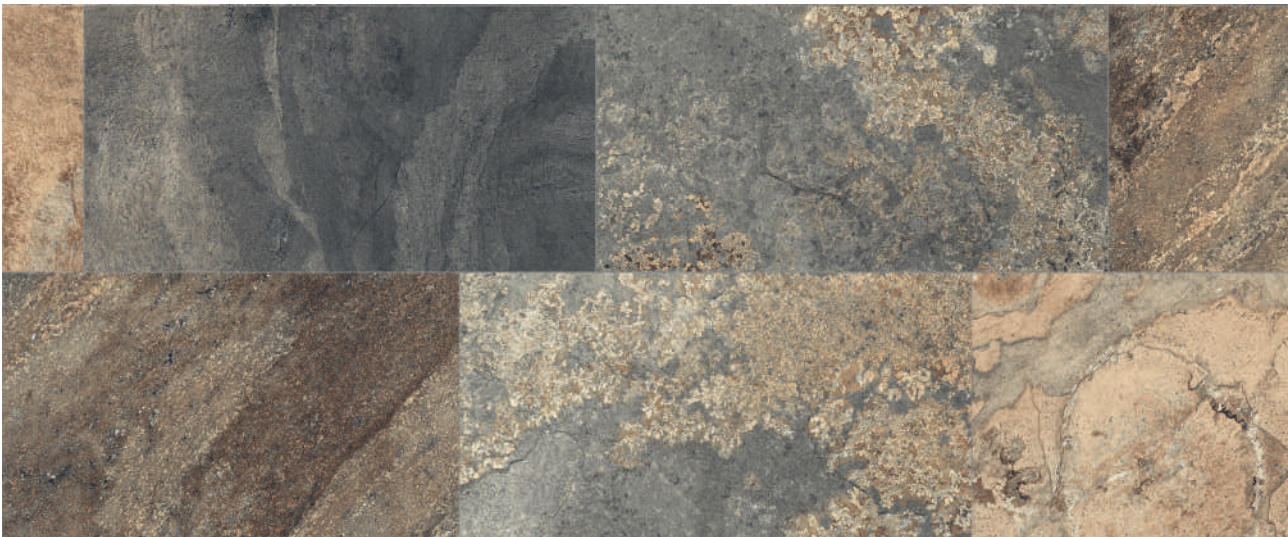

Formatos | Formats



↗ ↙ 60x120cm 23.6"x47.2"

C3 R11 · C1 R9 · R

C3 · C1 Cupira Hueso

C3 Cupira Marengo

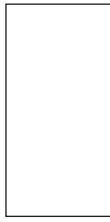

↗ ↙ 37.5x75cm 14.7"x29.5"

C3 R11 · R

Cupira Hueso

Cupira Marengo

Cupira Multi



↗ ↙ 14.7x14.7cm 5.7"x5.7"

C3 R11

Cupira Marengo

Cupira Multi

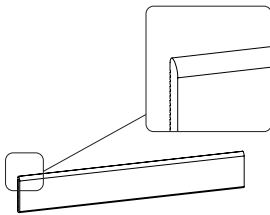

Rodapié
Skirting board

↗ ↙ 9x60cm 3.5"x23.6"

Coated Top

Cupira Hueso

Cupira Marengo

Cupira Multi

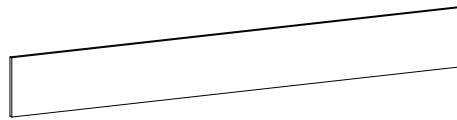

Tabica
Riser

↗ ↙ 14.5x120cm 3.5"x47.2"

Cupira Hueso

Cupira Marengo

Cupira Multi

Embalaje | Packing

Formatos Formats	piezas / caja pieces / box	m ² / caja sqm / box	kg / caja kg / box	m ² / palet sqm / pallet	tamaño palet pallet size
60x120 ^R cm 23.6"x47.2"	2	1,4400	31,65	46,08	120x84x74cm
37.5x75 ^R cm 14.7"x29.5"	4	1,1250	23,50	61,87	120x80x89cm
14.7x14.7 ^R cm 5.7"x5.7"	44	0,9508	16,97	76,06	120x80x89cm
9x60cm 3.5"x23.6"	10	-	15,36	-	110x95x96cm
Rodapié Skirting board					
14.5x120cm 3.5"x47.2"	6	-	22,20	-	125x110x90cm
Tabica Riser					

Colores junta recomendados | Recommended joint colours

Cupira Hueso
Mapei 100 White
Kerakoll 01 Blanco
Litokol White 1
SikaCeram Blanco

Cupira Marengo
Mapei 111 Silver Grey
Kerakoll 04 Gris Hierro
Litokol Silver 2
SikaCeram Perla

Cupira Multi
Mapei 113 Cement Grey
Kerakoll 05 Antracita
Litokol Silver 3
SikaCeram Cemento

Peldaños | Steps

Peldaño recto | Recto step



↗ ↘ 32.6x120cm 12.8"x47.2"

C3 R11

C1 R9

 Cupira Hueso

 Cupira Hueso

 Cupira Marengo

 Cupira Multi

Peldaño recto tapa | Recto step corner



↗ ↘ 32.6x120cm 12.8"x47.2"

C3 R11

C1 R9

 Cupira Hueso

 Cupira Hueso

 Cupira Marengo

 Cupira Multi

Bordes de piscina | Pool edges

Borde Creta | Creta edge



 32.6x50cm 12.8"x19.7"

C3 **R11** • 

 Cupira Hueso

 Cupira Marengo

 Cupira Multi

Rejillas de drenaje | Drain grates

Rejilla de drenaje RJ25 | Drain grate RJ25



 24,5x50cm 9,6"x19.7"

C3 **R11** •  

 Cupira Hueso

 Cupira Marengo

 Cupira Multi

Desagüe | Drain: >13m³/hora

Goma para rejilla 9134 incluida
Grate rubber 9134 included

Rejilla de drenaje RJ25 FLEX | Drain grate RJ25 FLEX



 24,5x50cm 9,6"x19.7"

C3 **R11** •  

 Cupira Hueso

 Cupira Marengo

 Cupira Multi

Desagüe | Drain: >30m³/hora

Goma para rejilla 9134 incluida
Grate rubber 9134 included

Goma para rejilla 9710 | Grate rubber 9710



Goma para rejilla 9134 | Grate rubber 9134



Piezas de terminación | Trims

Media caña exterior
Outer trims



-  4.5x50cm 1.8"x19.7"
- C3 R11** • Ref. MDCA E000
-  Cupira Hueso
-  Cupira Marengo
-  Cupira Multi

Escocia cantonera exterior
Scoth external corner



-  4.5x4.5cm 1.8"x1.8"
- C3 R11** • Ref. MDCA EE00
-  Cupira Hueso
-  Cupira Marengo
-  Cupira Multi

Esquina cantonera exterior
Outer angle corner



-  6.5x6.5cm 2.6"x2.6"
- C3 R11** • Ref. MDCA AE00
-  Cupira Hueso
-  Cupira Marengo
-  Cupira Multi

Media caña interior
Inner trims



-  5.5x50cm 2.2"x19.7"
- C3 R11** • Ref. MDCA I000
-  Cupira Hueso
-  Cupira Marengo
-  Cupira Multi

Escocia cantonera interior
Scoth inner corner



-  5.5x5.5cm 2.2"x2.2"
- C3 R11** • Ref. MDCA EI00
-  Cupira Hueso
-  Cupira Marengo
-  Cupira Multi





Esquina cantonera interior
Inner angle corner



-  6.5x6.5cm 2.6"x2.6"
- C3 R11** • Ref. MDCA AI00
-  Cupira Hueso
-  Cupira Marengo
-  Cupira Multi





Cantonera transición exterior
External transition corner

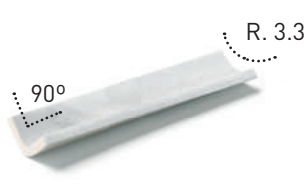

-  4.5x25cm 1.8"x9.8"
- C3 R11** • Ref. MDCA CE00
-  Cupira Hueso
-  Cupira Marengo
-  Cupira Multi

Cantonera transición interior
Inner transition corner



-  5.5x25cm 2.2"x9.8"
- C3 R11** • Ref. MDCA CI00
-  Cupira Hueso
-  Cupira Marengo
-  Cupira Multi

*Información detallada sobre las piezas de terminación en las páginas 212 y 213.
*Detailed information about trims pieces in pages 212 and 213.



Salem

Colección
Collection

Nuestra colección Salem está basada en la piedra Mallorca, conocida como "El Marés", de las Islas Baleares. Es una arenisca compuesta de fragmentos acumulados en su superficie que la dotan de una estructura y aspecto granular arenoso. Nuestra elección de tonos, Clar y Dune, abarca todo su color original, manteniendo la pureza de la piedra, apta para proyectos de gran diversidad gracias a sus tonos cálidos y fondo suave.

Our Salem collection is based on the Mallorca stone, known as "El Marés", from the Balearic Islands. It is a sandstone composed of fragments accumulated on its surface that give it a sandy granular structure and appearance. Our choice of tones, Clar and Dune, covers all its original colour, maintaining the purity of the stone, suitable for projects of great diversity thanks to its warm tones and soft background.

Salem Clar

Color | Colour



Salem Dune

Color | Colour



Montaje de suelo | Floor simulation

Salem Clar



Salem Dune



Formatos | Formats

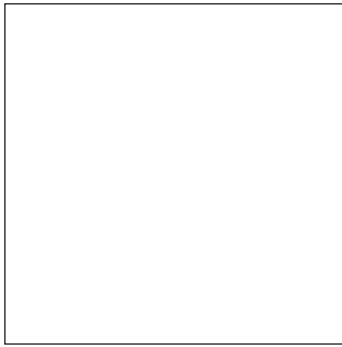

↙ ↘ 120x120cm 47.2"x47.2"



Salem Clar
 Salem Dune

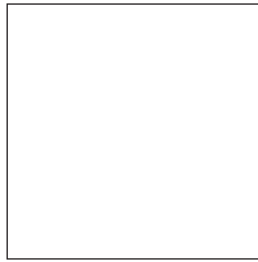

↙ ↘ 90x90cm 35.4"x35.4"



Salem Clar
 Salem Dune

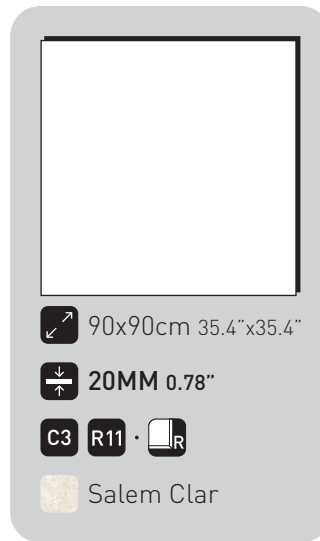

↙ ↘ 90x90cm 35.4"x35.4"

↕ 20MM 0.78"



Salem Clar

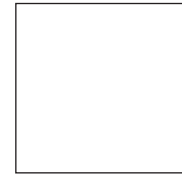

↙ ↘ 60x60cm 23.6"x23.6"



Salem Clar



↙ ↘ 60x120cm 23.6"x47.2"



Salem Clar
 Salem Dune

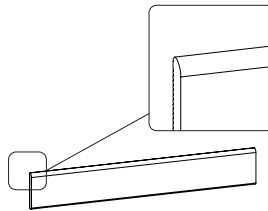

Rodapié
Skirting board

↙ ↘ 9x60cm 3.5"x23.6"

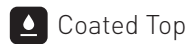

Salem Clar
 Salem Dune



Tabica
Riser

↙ ↘ 14.5x120cm 3.5"x47.2"

Salem Clar
 Salem Dune

Embalaje | Packing

Formatos Formats	piezas / caja pieces / box	m ² / caja sqm / box	kg / caja kg / box	m ² / palet sqm / pallet	tamaño palet pallet size
120x120 ^R cm 47.2"x47.2"	1	1,4400	31,00	57,60	120x84x74cm
90x90 ^R cm 35.4"x35.4"	2	1,6200	32,50	48,60	106x95x74cm
90x90 ^R 2CM 35.4"x35.4"x0.78"	1	0,8100	39,00	21,87	105x95x84cm
60x60 ^R cm 23.6"x23.6"	4	1,4400	27,00	46,08	120x80x74cm
60x120 ^R cm 23.6"x47.2"	2	1,4400	31,65	46,08	135x121x58cm
9x60cm 3.5"x23.6"	10	-	15,36	-	110x95x96cm
Rodapié Skirting board					
14.5x120cm 3.5"x47.2"	6	-	22,20	-	125x110x90cm

Tabica | Riser

Colores junta recomendados | Recommended joint colours



Salem Clar

Mapei 130 Jasmine
Kerakoll 31 Beige Dakar
Litokol Ivory 3
SikaCeram Arena



Salem Dune

Mapei 132 Beige 2000
Kerakoll 08 Beige Bahama
Litokol Beige 1
SikaCeram Caramelo

Peldaños | Steps

Peldaño recto | Recto step



↗ 32.6x120cm 12.8"x47.2"

C3 R11 · C1 R9

■ Salem Clar

■ Salem Dune

Peldaño recto tapa | Recto step corner



↗ 32.6x120cm 12.8"x47.2"

C3 R11 · C1 R9

■ Salem Clar

■ Salem Dune

Bordes de piscina | Pool edges

Borde Creta | Creta edge



↗ 32.6x50cm 12.8"x19.7"

C3 R11 · 🚰

☐ Salem Clar

☐ Salem Dune

Borde Maui | Maui edge



↗ 32.6x50cm 12.8"x19.7"

C3 R11 · 🚰

☐ Salem Clar

Borde Samoa | Samoa edge



↗ 50x120cm 19.7"x47.6"

C3 R11 · 🚰

☐ Salem Clar

Rejillas de drenaje | Drain grates

Rejilla de drenaje RJ20 | Drain grate RJ20



↗ 19.3x50cm 7.6"x19.7" Desagüe | Drain: >11m³/hora
 C3 R11 · 🌿 🌐
 Goma para rejilla 9134 incluida
 Grate rubber 9134 included
 Salem Clar

Rejilla de drenaje RJ20 FLEX | Drain grate RJ20 FLEX



↖ 19.3x50cm 7.6"x19.7" Desagüe | Drain: >30m³/hora
 C3 R11 · 🌿 🌐
 Goma para rejilla 9134 incluida
 Grate rubber 9134 included
 Salem Clar

Rejilla de drenaje RJ25 | Drain grate RJ25



↗ 24,5x50cm 9,6"x19,7" Desagüe | Drain: >13m³/hora
 C3 R11 · 🌿 🌐
 Goma para rejilla 9134 incluida
 Grate rubber 9134 included
 Salem Clar
 Salem Dune

Rejilla de drenaje RJ25 FLEX | Drain grate RJ25 FLEX



↗ 24,5x50cm 9,6"x19,7" Desagüe | Drain: >30m³/hora
 C3 R11 · 🌿 🌐
 Goma para rejilla 9134 incluida
 Grate rubber 9134 included
 Salem Clar
 Salem Dune

Rejilla de drenaje RJ25 INV | Drain grate RJ25 INV



↗ 24,5x50cm 9,6"x19,7" Desagüe | Drain: >8m³/hora
 C3 R11 · 🌿 🌐 🌧️
 Goma para rejilla 12719 incluida
 Grate rubber 12719 included
 Salem Clar

Goma para rejilla 9710 Grate rubber 9710



Goma para rejilla 9134 Grate rubber 9134





Goma para rejilla 12719 | Grate rubber 12719



Piezas de terminación | Trims



Media caña exterior
Outer trims



-  4.5x50cm 1.8"x19.7"
- C3 R11** • Ref. MDCA E000
-  Salem Clar
-  Salem Dune



Escocia cantonera exterior
Scotch external corner



-  4.5x4.5cm 1.8"x1.8"
- C3 R11** • Ref. MDCA EE00
-  Salem Clar
-  Salem Dune



Esquina cantonera exterior
Outer angle corner



-  6.5x6.5cm 2.6"x2.6"
- C3 R11** • Ref. MDCA AE00
-  Salem Clar
-  Salem Dune



Media caña interior
Inner trims



-  5.5x50cm 2.2"x19.7"
- C3 R11** • Ref. MDCA I000
-  Salem Clar
-  Salem Dune



Escocia cantonera interior
Scotch inner corner



-  5.5x5.5cm 2.2"x2.2"
- C3 R11** • Ref. MDCA EI00
-  Salem Clar
-  Salem Dune



Esquina cantonera interior
Inner angle corner



-  6.5x6.5cm 2.6"x2.6"
- C3 R11** • Ref. MDCA AI00
-  Salem Clar
-  Salem Dune



Cantonera transición exterior
External transition corner

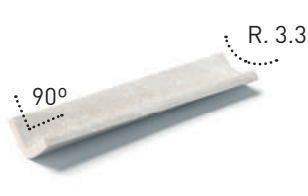

-  4.5x25cm 1.8"x9.8"
- C3 R11** • Ref. MDCA CE00
-  Salem Clar
-  Salem Dune

Cantonera transición interior
Inner transition corner



-  5.5x25cm 2.2"x9.8"
- C3 R11** • Ref. MDCA CI00
-  Salem Clar
-  Salem Dune

*Información detallada sobre las piezas de terminación en las páginas 212 y 213.
*Detailed information about trims pieces in pages 212 and 213.



CORALINA SAMANÁ

Coralina

Colección
Collection

La Coralina es una piedra originaria del Caribe, formada a partir de corales fósiles y otros animales marinos desprendidos de los arrecifes y depositados en los lechos marinos de piedra caliza. La colección contiene dos tonos: Samaná, su color original, y Aguada, neutro. Esta piedra está totalmente integrada en el estilo arquitectónico y escultórico local. Idónea para utilizar en muy diferentes entornos para Diseñadores/Interioristas/Arquitectos sin importar la envergadura.

Coralina is a stone native to the Caribbean, formed from fossil corals and other marine animals that have broken off from reefs and been deposited on limestone seabeds. The collection contains two shades: Samaná, its original colour, and Aguada, neutral. This stone is fully integrated into the local architectural and sculptural style. Suitable for use in many different environments for Designers/Interiorists/Architects of all sizes.

Coralina Aguada

Color | Colour



Coralina Samaná

Color | Colour



Montaje de suelo | Floor simulation

Coralina Aguada



Coralina Samaná



Formatos | Formats

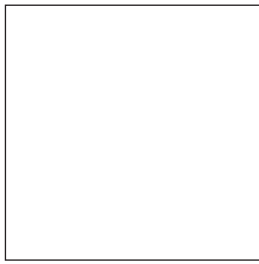

↗ 90x90cm 35.4"x35.4"



Coralina Aguada

Coralina Samaná

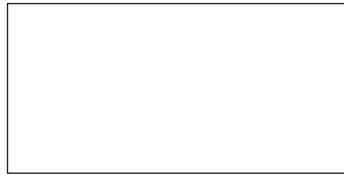

↗ 60x120cm 23.6"x47.2"



Coralina Aguada

Coralina Samaná

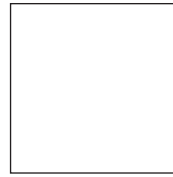

↗ 60x60cm 23.6"x23.6"



Coralina Aguada

Coralina Samaná

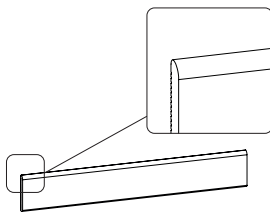

Rodapié
Skirting board

↗ 9x60cm 3.5"x23.6"

Coated Top

Coralina Aguada

Coralina Samaná

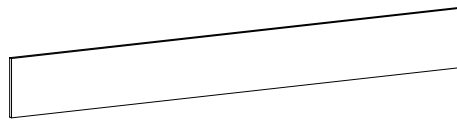

Tabica
Riser

↗ 14.5x120cm 3.5"x47.2"

Coralina Aguada

Coralina Samaná

Embalaje | Packing

Formatos Formats	piezas / caja pieces / box	m ² / caja sqm / box	kg / caja kg / box	m ² / palet sqm / pallet	tamaño palet pallet size
90x90 ^R cm 35.4"x35.4"	2	1,6200	32,50	48,60	106x95x74cm
60x120 ^R cm 23.6"x47.2"	2	1,4400	31,65	46,08	120x84x74cm
60x60 ^R cm 23.6"x23.6"	4	1,4400	27,00	46,08	120x80x74cm
9x60cm 3.5"x23.6"	10	-	15,36	-	110x95x96cm
Rodapié Skirting board					
14.5x120cm 3.5"x47.2"	6	-	22,20	-	125x110x90cm
Tabica Riser					

Colores junta recomendados | Recommended joint colours

Coralina Aguada
Mapei 130 Jasmine
Kerakoll 31 Beige Dakar
Litokol Ivory 2
SikaCeram Arena

Coralina Samaná
Mapei 132 Beige 2000
Kerakoll 08 Beige Bahama
Litokol Beige 1
SikaCeram Caramelo

Peldaños | Steps

Peldaño recto | Recto step



↗ 32.6x120cm 12.8"x47.2"

C3 R11 · C1 R9

■ Coralina Aguada

■ Coralina Samaná

Peldaño recto tapa | Recto step corner



↗ 32.6x120cm 12.8"x47.2"

C3 R11 · C1 R9

■ Coralina Aguada

■ Coralina Samaná

Bordes de piscina | Pool edges

Borde Creta | Creta edge



↗ 32.6x50cm 12.8"x19.7"

C3 R11 · 🚰

■ Coralina Aguada

■ Coralina Samaná

Rejillas de drenaje | Drain grates

Rejilla de drenaje RJ25 | Drain grate RJ25



↗ 24,5x50cm 9,6"x19.7"

Desagüe | Drain: >13m³/hora



Goma para rejilla 9134 incluida
Grate rubber 9134 included

 Coralina Aguada

 Coralina Samaná

Goma para rejilla 9710 | Grate rubber 9710



Rejilla de drenaje RJ25 FLEX | Drain grate RJ25 FLEX



↗ 24,5x50cm 9,6"x19.7"

Desagüe | Drain: >30m³/hora



Goma para rejilla 9134 incluida
Grate rubber 9134 included

 Coralina Aguada

 Coralina Samaná

Goma para rejilla 9134 | Grate rubber 9134



Rejilla de drenaje RJ25 INV | Drain grate RJ25 INV



↗ 24,5x50cm 9,6"x19.7"

Desagüe | Drain: >8m³/hora



Goma para rejilla 12719 incluida
Grate rubber 12719 included

 Coralina Aguada

 Coralina Samaná



Goma para rejilla 12719 | Grate rubber 12719



Piezas de terminación | Trims



Media caña exterior
Outer trims



-  4.5x50cm 1.8"x19.7"
- C3 R11** • Ref. MDCA E000
-  Coralina Aguada
-  Coralina Samaná



Escocia cantonera exterior
Scotch external corner



-  4.5x4.5cm 1.8"x1.8"
- C3 R11** • Ref. MDCA EE00
-  Coralina Aguada
-  Coralina Samaná

Esquina cantonera exterior
Outer angle corner



-  6.5x6.5cm 2.6"x2.6"
- C3 R11** • Ref. MDCA AE00
-  Coralina Aguada
-  Coralina Samaná



Media caña interior
Inner trims



-  5.5x50cm 2.2"x19.7"
- C3 R11** • Ref. MDCA I000
-  Coralina Aguada
-  Coralina Samaná



Escocia cantonera interior
Scotch inner corner



-  5.5x5.5cm 2.2"x2.2"
- C3 R11** • Ref. MDCA EI00
-  Coralina Aguada
-  Coralina Samaná



Esquina cantonera interior
Inner angle corner



-  6.5x6.5cm 2.6"x2.6"
- C3 R11** • Ref. MDCA AI00
-  Coralina Aguada
-  Coralina Samaná



Cantonera transición exterior
External transition corner

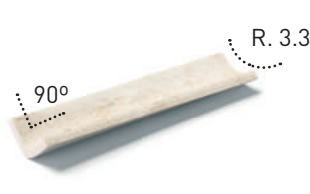

-  4.5x25cm 1.8"x9.8"
- C3 R11** • Ref. MDCA CE00
-  Coralina Aguada
-  Coralina Samaná

Cantonera transición interior
Inner transition corner



-  5.5x25cm 2.2"x9.8"
- C3 R11** • Ref. MDCA CI00
-  Coralina Aguada
-  Coralina Samaná

*Información detallada sobre las piezas de terminación en las páginas 212 y 213.
*Detailed information about trims pieces in pages 212 and 213.





LAO ASH

Lao

Colección
Collection

Nuestra colección Lao surge de la piedra caliza Caramiel, originaria de España. Su fondo regular está combinado con variadas manchas, incrustaciones y oquedades. Todas ellas, originariamente en tonos beige y cremas con diferentes tamaños e intensidades que se pueden encontrar en mayor o menores agrupaciones, dotando a las piezas de un efecto de movimiento y continuidad constante. Desarrollada en tres tonos principales: Bone, Sand y Ash, inclusivos en cualquier espacio decorativo tanto de exterior como interior.

Our Lao collection is made from Caramiel limestone, originally from Spain. Its regular background is combined with various stains, incrustations and hollows. All of them, originally in beige and cream tones with different sizes and intensities that can be found in larger or smaller groupings, giving the pieces an effect of movement and constant continuity. Developed in three main shades: Bone, Sand and Ash, inclusive in any decorative space, both outdoors and indoors.

Lao Bone

Color | Colour



Lao Sand

Color | Colour



Lao Ash

Color | Colour



Montaje de suelo | Floor simulation

Lao Bone



Lao Sand



Lao Ash



Formatos | Formats

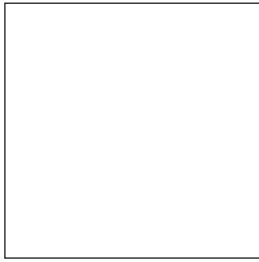

↗ 90x90cm 35.4"x35.4"



 Lao Bone

 Lao Sand

 Lao Ash

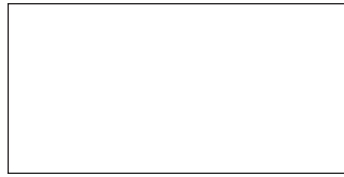

↗ 60x120cm 23.6"x47.2"



 Lao Bone

 Lao Sand

 Lao Ash

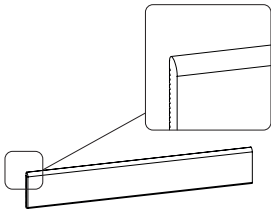

Rodapié
Skirting board

↗ 9x60cm 3.5"x23.6"

 Coated Top

 Lao Bone

 Lao Sand

 Lao Ash

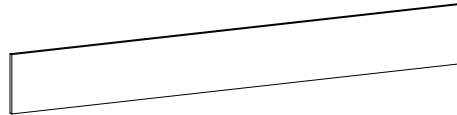

Tabica
Riser

↗ 14.5x120cm 3.5"x47.2"

 Lao Bone

 Lao Sand

 Lao Ash

Embalaje | Packing

Formatos Formats	piezas / caja pieces / box	m ² / caja sqm / box	kg / caja kg / box	m ² / palet sqm / pallet	tamaño palet pallet size
90x90 ^R cm 35.4"x35.4"	2	1,6200	32,50	48,60	106x95x74cm
60x120 ^R cm 23.6"x47.2"	2	1,4400	31,65	46,08	120x84x74cm
9x60cm 3.5"x23.6"	10	-	15,36	-	
Rodapié Skirting board					110x95x96cm
14.5x120cm 3.5"x47.2"	6	-	22,20	-	
Tabica Riser					125x110x90cm

Colores junta recomendados | Recommended joint colours

 Lao Bone

Mapei 100 White
Kerakoll 01 Blanco
Litokol White 1
SikaCeram Blanco

 Lao Sand

Mapei 130 Jasmine
Kerakoll 31 Beige Dakar
Litokol Ivory 2
SikaCeram Arena

 Lao Ash

Mapei 112 Medium Grey
Kerakoll 04 Gris Hierro
Litokol Silver 2
SikaCeram Cemento

Peldaños | Steps

Peldaño recto | Recto step

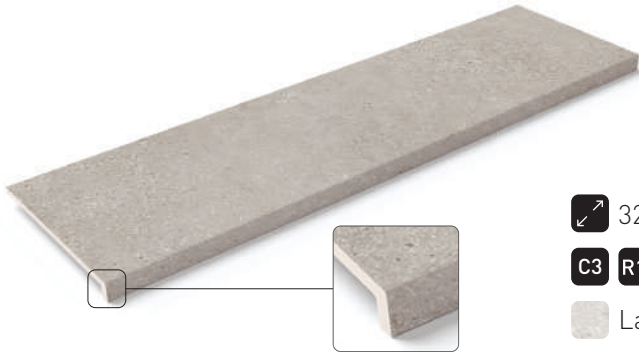

↗ ↙ 32.6x120cm 12.8"x47.2"

C3 R11 · C1 R9

■ Lao Bone

■ Lao Sand

■ Lao Ash

Peldaño recto tapa | Recto step corner



↗ ↙ 32.6x120cm 12.8"x47.2"

C3 R11 · C1 R9

■ Lao Bone

■ Lao Sand

■ Lao Ash

Bordes de piscina | Pool Edges

Borde Creta | Creta edge



↗ ↙ 32.6x50cm 12.8"x19.7"

C3 R11 · 🚰

🟤 Lao Bone

🟡 Lao Sand

🟢 Lao Ash

Borde Maui | Maui edge



↗ ↙ 32.6x50cm 12.8"x19.7"

C3 R11 · 🚰

🟤 Lao Bone

🟡 Lao Sand

🟢 Lao Ash

Borde Samoa | Samoa edge



↗ ↙ 50x120cm 19.7"x47.6"

C3 R11 · 🚰

🟤 Lao Bone

🟡 Lao Sand

🟢 Lao Ash

Rejillas de drenaje | Drain Grates

Rejilla de drenaje RJ25 | Drain grate RJ25



 24,5x50cm 9,6"x19.7"

C3 **R11** ·  

 Lao Bone

 Lao Sand

 Lao Ash

Desagüe | Drain: >13m³/hora

Goma para rejilla 9134 incluida
Grate rubber 9134 included

Goma para rejilla 9710 | Grate rubber 9710



Rejilla de drenaje RJ25 FLEX | Drain grate RJ25 FLEX



 24,5x50cm 9,6"x19.7"

C3 **R11** ·  

 Lao Bone

 Lao Sand

 Lao Ash

Desagüe | Drain: >30m³/hora

Goma para rejilla 9134 incluida
Grate rubber 9134 included





Goma para rejilla 9134 | Grate rubber 9134



Piezas de terminación | Trims





Media caña exterior
Outer trims



-  4.5x50cm 1.8"x19.7"
- C3 R11** • Ref. MDCA E000
-  Lao Bone
-  Lao Sand
-  Lao Ash





Escocia cantonera exterior
Scotch external corner



-  4.5x4.5cm 1.8"x1.8"
- C3 R11** • Ref. MDCA EE00
-  Lao Bone
-  Lao Sand
-  Lao Ash





Esquina cantonera exterior
Outer angle corner



-  6.5x6.5cm 2.6"x2.6"
- C3 R11** • Ref. MDCA AE00
-  Lao Bone
-  Lao Sand
-  Lao Ash





Media caña interior
Inner trims



-  5.5x50cm 2.2"x19.7"
- C3 R11** • Ref. MDCA I000
-  Lao Bone
-  Lao Sand
-  Lao Ash





Escocia cantonera interior
Scotch inner corner



-  5.5x5.5cm 2.2"x2.2"
- C3 R11** • Ref. MDCA EI00
-  Lao Bone
-  Lao Sand
-  Lao Ash





Esquina cantonera interior
Inner angle corner



-  6.5x6.5cm 2.6"x2.6"
- C3 R11** • Ref. MDCA AI00
-  Lao Bone
-  Lao Sand
-  Lao Ash





Cantonera transición exterior
External transition corner

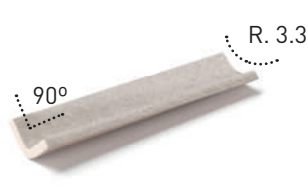

-  4.5x25cm 1.7"x6.3"
- C3 R11** • Ref. MDCA CE00
-  Lao Bone
-  Lao Sand
-  Lao Ash

Cantonera transición interior
Inner transition corner



-  5.5x25cm 2.2"x9.8"
- C3 R11** • Ref. MDCA CI00
-  Lao Bone
-  Lao Sand
-  Lao Ash

*Información detallada sobre las piezas de terminación en las páginas 212 y 213.
*Detailed information about trims pieces in pages 212 and 213.



LAO BONE



ETERNA CENDRA | ETERNA ALBA

Eterna

Colección
Collection

La colección Eterna está inspirada en la piedra Fior Di Bosco, extraída de las canteras ubicadas en la Toscana. Su tono original es un elegante gris, repleto de matices plumizos y humo donde se intercalan vetas arborescentes en tonos blancos y ocre. La colección aporta sofisticación y serenidad. Con sus tres colores, abarcamos del tono origen y clásico Cendra, a una visión afín a tendencias actuales como el Argent y Alba. Es perfecta para grandes proyectos, tanto para interiores como exteriores, en residenciales y construcciones hoteleras de lujo.

The Eterna collection is inspired by Fior Di Bosco stone, extracted from quarries in Tuscany. Its original tone is an elegant grey, full of leaden and smoky nuances interspersed with tree-like veins in shades of white and ochre. The collection brings sophistication and serenity. With its three colours, we range from the original and classic Cendra tone, to a vision in line with current trends such as Argent and Alba. It is perfect for large projects, both for interiors and exteriors, in residential and luxury hotel constructions.

Eterna Alba

Color | Colour



Eterna Argent

Color | Colour



Eterna Cendra

Color | Colour



Montaje de suelo | Floor simulation

Eterna Alba



Eterna Argent



Eterna Cendra



Formatos | Formats



60x120cm 23.6"x47.2"

C3 **R11** · **C1** **R9** ·

Eterna Alba

Eterna Argent

Eterna Cendra

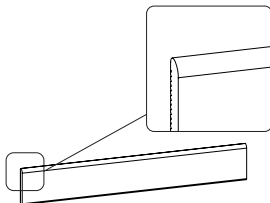

Rodapié
Skirting board

9x60cm 3.5"x23.6"

Coated Top

Eterna Alba

Eterna Argent

Eterna Cendra



Tabica
Riser

14.5x120cm 3.5"x47.2"

Eterna Alba

Eterna Argent

Eterna Cendra

Embalaje | Packing

Formatos Formats	piezas / caja pieces / box	m ² / caja sqm / box	kg / caja kg / box	m ² / palet sqm / pallet	tamaño palet pallet size
60x120 ^o cm 23.6"x47.2"	2	1,4400	31,65	46,08	120x84x74cm
9x60cm 3.5"x23.6"	10	-	15,36	-	110x95x96cm
Rodapié Skirting board					
14.5x120cm 3.5"x47.2"	6	-	22,20	-	125x110x90cm
Tabica Riser					

Colores junta recomendados | Recommended joint colours

Eterna Alba
Mapei 100 White
Kerakoll 01 Blanco
Litokol White 1
SikaCeram Blanco

Eterna Argent
Mapei 113 Cement Grey
Kerakoll 04 Gris Hierro
Litokol Silver 3
SikaCeram Cemento

Eterna Cendra
Mapei 114 Anthracite
Kerakoll 05 Antracita
Litokol Black 1
SikaCeram Antracita

Peldaños | Steps

Peldaño recto | Recto step



↙ ↗ 32.6x120cm 12.8"x47.2"

C3 R11 · C1 R9

Eterna Alba

Eterna Argent

Eterna Cendra

Peldaño recto tapa | Recto step corner



↙ ↗ 32.6x120cm 12.8"x47.2"

C3 R11 · C1 R9

Eterna Alba

Eterna Argent

Eterna Cendra



ICONIC STONE

Iconic

Colección
Collection

Iconic nace de la piedra Grigio Venato de los Alpes, manteniendo su fuerza original. Cada cara resalta las características vetas blancas entremezcladas con su rico fondo. Una colección con personalidad, ideal para diseñadores y arquitectos que buscan un material protagonista. Iconic se centra en el color Stone, el concepto de la piedra Grigio en único tono, para una colección única.

Iconic is born from the Grigio Venato stone of the Alps, maintaining its original strength. Each face highlights the characteristic white veins interspersed with its rich background. A collection with personality, ideal for designers and architects looking for a protagonist material. Iconic focuses on the Stone colour, the concept of Grigio stone in a single tone, for a unique collection.

Iconic Stone

Color | Colour



Montaje de suelo | Floor simulation

Iconic Stone



Formatos | Formats

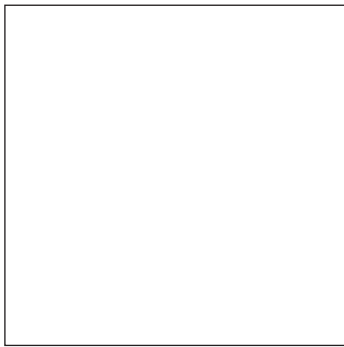

120x120cm 47.2"x47.2"

C3 **R11** · **C1** **R9** ·

Iconic Stone



60x120cm 23.6"x47.2"

C3 **R11** · **C1** **R9** ·

Iconic Stone

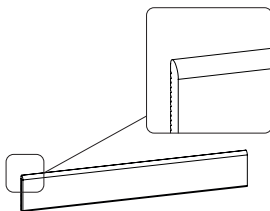

Rodapié
Skirting board

9x60cm 3.5"x23.6"

Coated Top

Iconic Stone



Tabica
Riser

14.5x120cm 3.5"x47.2"

Iconic Stone

Embalaje | Packing

Formatos Formats	piezas / caja pieces / box	m ² / caja sqm / box	kg / caja kg / box	m ² / palet sqm / pallet	tamaño palet pallet size
120x120 ^R cm 47.2"x47.2"	1	1,4400	31,00	57,60	135x121x58cm
60x120 ^R cm 23.6"x47.2"	2	1,4400	31,65	46,08	120x84x74cm
9x60cm 3.5"x23.6"	10	-	15,36	-	110x95x96cm
Rodapié Skirting board					
14.5x120cm 3.5"x47.2"	6	-	22,20	-	125x110x90cm
Tabica Riser					

Colores junta recomendados | Recommended joint colours

Iconic Stone

Mapei 110 Manhattan 2000
Kerakoll 04 Gris Hierro
Litokol Grey 1
SikaCeram Visión

Peldaños | Steps

Peldaño recto | Recto step



Peldaño recto tapa | Recto step corner



Bordes de piscina | Pool Edges

Borde Creta | Creta edge



↗ ↙ 32.6x50cm 12.8"x19.7"

C3 R11 · 🚰

🪨 Iconic Stone

Rejillas de drenaje | Drain Grates

Rejilla de drenaje RJ25 | Drain grate RJ25



↗ ↙ 24,5x50cm 9,6"x19.7"

C3 R11 · 🚰 🌐

🪨 Iconic Stone

Desagüe | Drain: >13m³/hora

Goma para rejilla 9134 incluida
Grate rubber 9134 included

Goma para rejilla 9710 | Grate rubber 9710



Rejilla de drenaje RJ25 FLEX | Drain grate RJ25 FLEX



↗ ↙ 24,5x50cm 9,6"x19.7"

C3 R11 · 🚰 🌐

🪨 Iconic Stone

Desagüe | Drain: >30m³/hora

Goma para rejilla 9134 incluida
Grate rubber 9134 included

Goma para rejilla 9134 | Grate rubber 9134



Piezas de terminación | Trims

Media caña exterior
Outer trims



↗ 4.5x50cm 1.8"x19.7"
C3 R11 • Ref. MDCA E000
 Iconic Stone

Escocia cantonera exterior
Scotch external corner



↗ 4.5x4.5cm 1.8"x1.8"
C3 R11 • Ref. MDCA EE00
 Iconic Stone

Esquina cantonera exterior
Outer angle corner



↗ 6.5x6.5cm 2.6"x2.6"
C3 R11 • Ref. MDCA AE00
 Iconic Stone

Media caña interior
Inner trims



↗ 5.5x50cm 2.2"x19.7"
C3 R11 • Ref. MDCA I000
 Iconic Stone

Escocia cantonera interior
Scotch inner corner



↗ 5.5x5.5cm 2.2"x2.2"
C3 R11 • Ref. MDCA EI00
 Iconic Stone

Esquina cantonera interior
Inner angle corner



↗ 6.5x6.5cm 2.6"x2.6"
C3 R11 • Ref. MDCA AI00
 Iconic Stone

Cantonera transición exterior
External transition corner



↗ 4.5x25cm 1.8"x9.8"
C3 R11 • Ref. MDCA CE00
 Iconic Stone

Cantonera transición interior
Inner transition corner

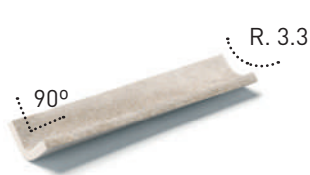

↗ 5.5x25cm 2.2"x9.8"
C3 R11 • Ref. MDCA CI00
 Iconic Stone

*Información detallada sobre las piezas de terminación en las páginas 212 y 213.
 *Detailed information about trims pieces in pages 212 and 213.



CALACATTA FRESH

Calacatta

Colección
Collection

Inspirada en el icónico mármol blanco italiano Calacatta sinónimo del Humanismo del Renacimiento, Calacatta presenta un cromatismo singular, en el que un blanco roto de fondo y unas variadas vetas de color gris claro se ven puntualmente salpicadas por notas ambarinas y doradas. Es un atemporal testimonio que nos recuerda con su belleza que los clásicos siempre vuelven para vestir elegantemente interiores y exteriores de lujo.

Inspired by the iconic white Italian Calacatta marble synonymous with Renaissance Humanism, Calacatta presents a singular chromaticism, in which an off-white background and varied light grey veins are punctuated by amber and golden notes. It is a timeless statement that reminds us with its beauty that the classics always come back to elegantly dress luxury interiors and exteriors.

Calacatta Fresh

Color | Colour



Montaje de suelo | Floor simulation

Calacatta Fresh



Formatos | Formats



↗ ↙ 60x120cm 23.6"x47.2"

C3 R11 · C1 R9 · R

■ Calacatta Fresh

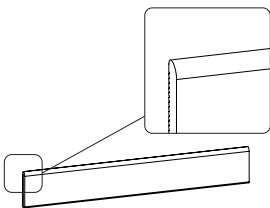

Rodapié
Skirting board

↗ ↙ 9x60cm 3.5"x23.6"

🔥 Coated Top

■ Calacatta Fresh



Tabica
Riser

↗ ↙ 14.5x120cm 3.5"x47.2"

■ Calacatta Fresh

Embalaje | Packing

Formatos Formats	piezas / caja pieces / box	m ² / caja sqm / box	kg / caja kg / box	m ² / palet sqm / pallet	tamaño palet pallet size
60x120 ^o cm 23.6"x47.2"	2	1,4400	31,65	46,08	120x84x74cm
9x60cm 3.5"x23.6"	10	-	15,36	-	110x95x96cm
Rodapié Skirting board					
14.5x120cm 3.5"x47.2"	6	-	22,20	-	125x110x90cm
Tabica Riser					

Colores junta recomendados | Recommended joint colours

■ Calacatta Fresh
Mapei 100 White
Kerakoll 01 Blanco
Litokol White 1
SikaCeram Blanco

Peldaños | Steps

Peldaño recto | Recto step

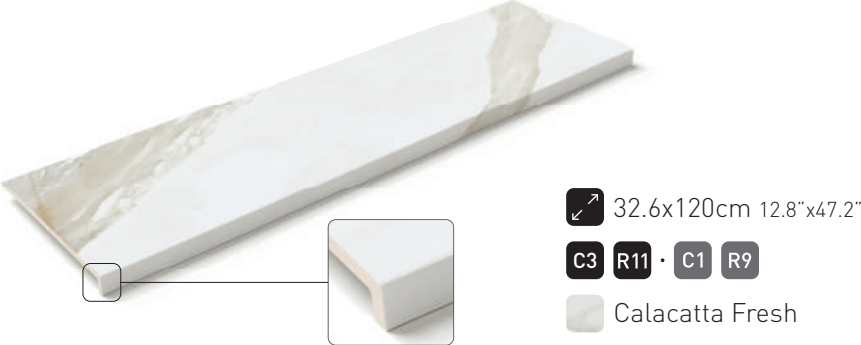

Peldaño recto tapa | Recto step corner





Cements

Colección
Collection

La colección Cements apuesta por un cemento muy personal que reproduce fielmente la textura. Los detalles imitan las variaciones en el grano con sutiles espatulados y marcas, agregando interés visual. La paleta de colores de la colección se centra en tonos que van del gris más identificativo, Smoke, pasando por matices cálidos como el Warm, y más neutro y ligero como el Snow. Está diseñada para un uso versátil, pudiendo instalarse tanto en interiores como en exteriores, permitiendo una continuidad visual.

The Cements collection features a very personal cement that faithfully reproduces the texture. Details mimic variations in the grain with subtle spatulations and markings, adding visual interest. The collection's colour palette focuses on shades ranging from the more identifiable grey, Smoke, through warm shades such as Warm, to more neutral and lighter shades such as Snow. It is designed for versatile use and can be installed both indoors and outdoors, providing visual continuity.

Cements Snow

Color | Colour



Cements Warm

Color | Colour



Cements Smoke

Color | Colour



Montaje de suelo | Floor simulation

Cements Snow



Cements Warm



Cements Smoke



Formatos | Formats

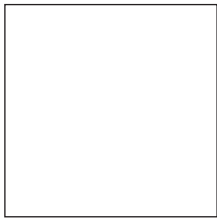

↗ 75x75cm 29.5"x29.5"

C3 R11 · C1 R9 ·

Cements Snow

Cements Warm

Cements Smoke

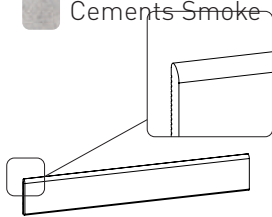

Rodapié
Skirting board

↗ 9x60cm 3.5"x23.6"

Coated Top

Cements Snow

Cements Warm

Cements Smoke

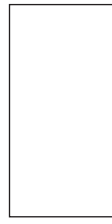

↗ 37.5x75cm 14.7"x29.5"

C3 R11 ·

Cements Snow

Cements Warm

Cements Smoke

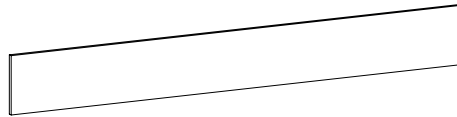

Tabica
Riser

↗ 14.5x120cm 3.5"x47.2"

Cements Snow

Cements Warm

Cements Smoke



↗ 60x120cm 23.6"x47.2"

C3 R11 · C1 R9 ·

Cements Snow

Embalaje | Packing

Formatos Formats	piezas / caja pieces / box	m ² / caja sqm / box	kg / caja kg / box	m ² / palet sqm / pallet	tamaño palet pallet size
75x75 ^R cm 29.5"x29.5"	2	1,1250	23,50	54,00	120x80x90cm
37.5x75 ^R cm 14.7"x29.5"	4	1,1250	23,50	61,87	120x80x89cm
60x120 ^R cm 23.6"x47.2"	2	1,4400	31,65	46,08	120x84x74cm
9x60cm 3.5"x23.6"	10	-	15,36	-	110x95x96cm
Rodapié Skirting board	-	-	-	-	-
14.5x120cm 3.5"x47.2"	6	-	22,20	-	125x110x90cm
Tabica Riser	-	-	-	-	-

Colores junta recomendados | Recommended joint colours

Cements Snow
Mapei 100 White
Kerakoll 01 Blanco
Litokol White 1
SikaCeram Blanco

Cements Warm
Mapei 142 Brown
Kerakoll 09 Caramelo
Litokol Beige 3
SikaCeram Caoba

Cements Smoke
Mapei 112 Medium Grey
Kerakoll 04 Gris Hierro
Litokol Silver 2
SikaCeram Cemento

Peldaños | Steps

Peldaño recto | Recto step

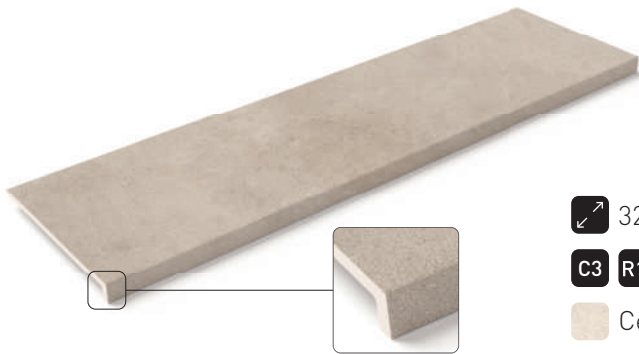

↗ 32.6x120cm 12.8"x47.2"

C3 R11 · C1 R9

Cements Snow

Cements Warm

Cements Smoke

Peldaño recto tapa | Recto step corner



↗ 32.6x120cm 12.8"x47.2"

C3 R11 · C1 R9

Cements Snow

Cements Warm

Cements Smoke

Bordes de piscina | Pool Edges

Borde Creta | Creta edge



 32.6x50cm 12.8"x19.7"

C3 **R11** · 

 Cements Snow

 Cements Warm

 Cements Smoke

Rejillas de drenaje | Drain Grates

Rejilla de drenaje RJ25 | Drain grate RJ25



 24,5x50cm 9,6"x19.7"

C3 **R11** ·  

 Cements Snow

 Cements Warm

 Cements Smoke

Desagüe | Drain: >13m³/hora

Goma para rejilla 9134 incluida
Grate rubber 9134 included

Goma para rejilla 9710 | Grate rubber 9710



Rejilla de drenaje RJ25 FLEX | Drain grate RJ25 FLEX



 24,5x50cm 9,6"x19.7"

C3 **R11** ·  

 Cements Snow

 Cements Warm

 Cements Smoke

Desagüe | Drain: >30m³/hora

Goma para rejilla 9134 incluida
Grate rubber 9134 included

Goma para rejilla 9134 | Grate rubber 9134



Piezas de terminación | Trims

Media caña exterior
Outer trims



-  4.5x50cm 1.8"x19.7"
- C3 R11** · Ref. MDCA E000
-  Cements Snow
-  Cements Warm
-  Cements Smoke

Escocia cantonera exterior
Scotch external corner



-  4.5x4.5cm 1.8"x1.8"
- C3 R11** · Ref. MDCA EE00
-  Cements Snow
-  Cements Warm
-  Cements Smoke





Esquina cantonera exterior
Outer angle corner



-  6.5x6.5cm 2.6"x2.6"
- C3 R11** · Ref. MDCA AE00
-  Cements Snow
-  Cements Warm
-  Cements Smoke

Media caña interior
Inner trims



-  5.5x50cm 2.2"x19.7"
- C3 R11** · Ref. MDCA I000
-  Cements Snow
-  Cements Warm
-  Cements Smoke

Escocia cantonera interior
Scotch inner corner



-  5.5x5.5cm 2.2"x2.2"
- C3 R11** · Ref. MDCA EI00
-  Cements Snow
-  Cements Warm
-  Cements Smoke





Esquina cantonera interior
Inner angle corner

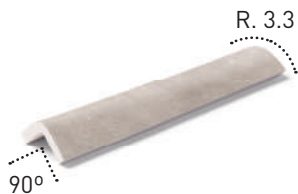

-  6.5x6.5cm 2.6"x2.6"
- C3 R11** · Ref. MDCA AI00
-  Cements Snow
-  Cements Warm
-  Cements Smoke





Cantonera transición exterior
External transition corner

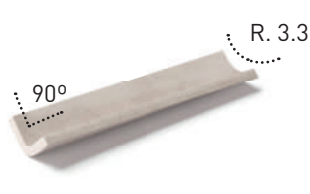

-  4.5x25cm 1.8"x9.8"
- C3 R11** · Ref. MDCA CE00
-  Cements Snow
-  Cements Warm
-  Cements Smoke

Cantonera transición interior
Inner transition corner



-  5.5x25cm 2.2"x9.8"
- C3 R11** · Ref. MDCA CI00
-  Cements Snow
-  Cements Warm
-  Cements Smoke

*Información detallada sobre las piezas de terminación en las páginas 212 y 213.
*Detailed information about trims pieces in pages 212 and 213.



COTTO BOHO

Cotto

Colección
Collection

El desarrollo del Cotto nace de la mezcla de piezas recuperadas en antiguas villas/caseríos demolidas junto a nuevas creaciones hechas a mano. La unión de todas ellas y un meticuloso tratamiento para suavizar su apariencia, aporta al conjunto un enfoque contemporáneo y de sólido carácter estético. La sostenibilidad, característica principal de la colección Cotto, es cada vez más valorada en cualquier entorno arquitectónico. Nuestro tono Boho, presenta una gama suave de colores cálidos y terrosos, que van desde los ocres y los ricos rojizos pasando por los beiges más calmados, que lo hacen apto para adaptarse a múltiples espacios tanto de exterior como de interior.

The development of the Cotto was born from the mixture of pieces recovered from old demolished villas/farm houses together with new handmade creations. The union of all of them and a meticulous treatment to soften their appearance, gives the whole a contemporary approach and a solid aesthetic character. Sustainability, a key feature of the Cotto collection, is increasingly valued in any architectural environment. Our Boho shade, featuring a soft range of warm, earthy colours from ochres and rich russets through to calmer beiges, is suitable for use in a variety of interior and exterior spaces.

Cotto Boho

Color | Colour



Montaje de suelo | Floor simulation

Cotto Boho

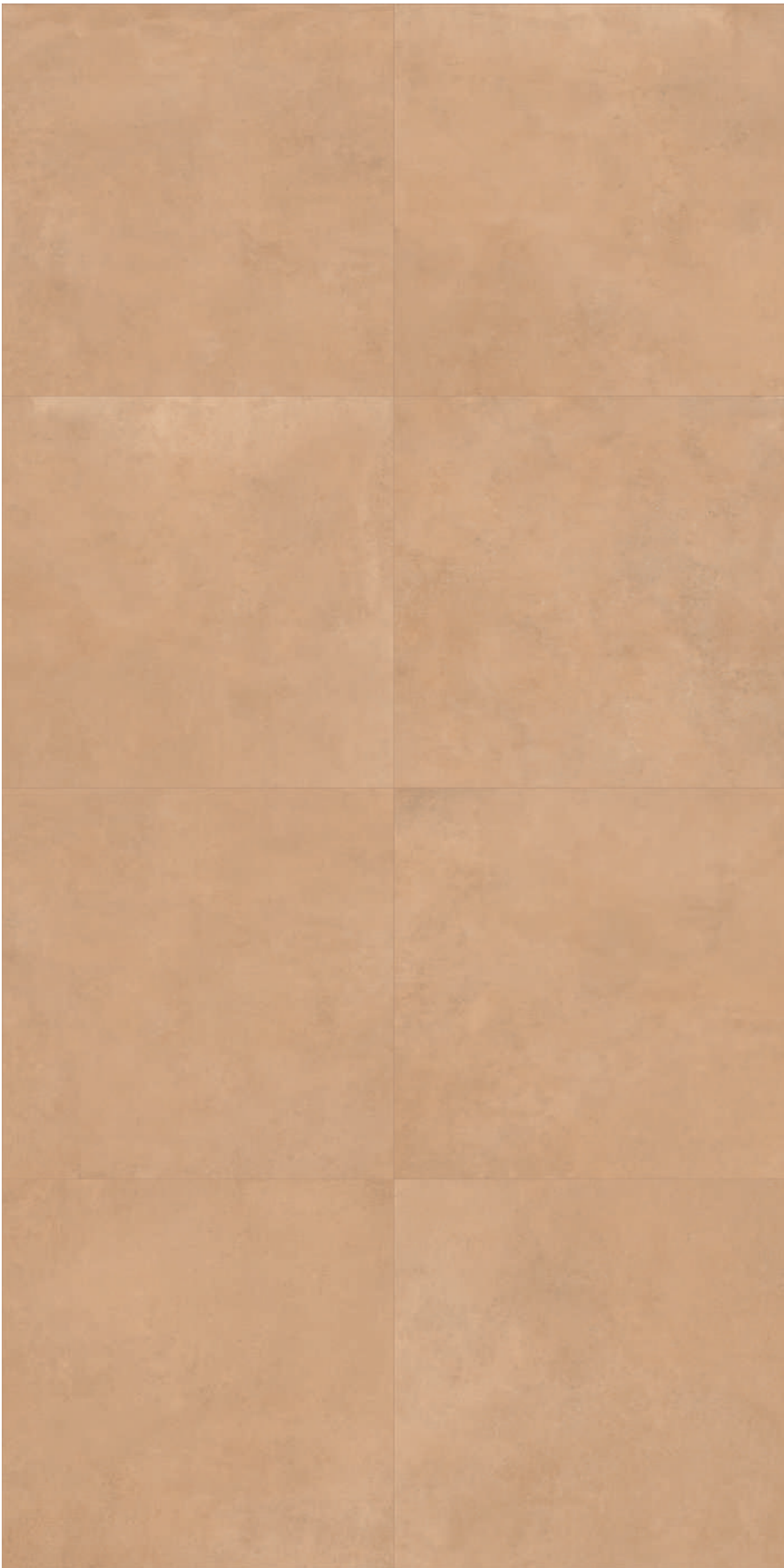

Formatos | Formats

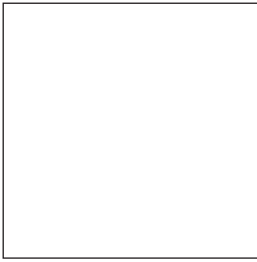

90x90cm 35.4"x35.4"

C3 **R11** · **C1** **R9** ·

Cotto Boho

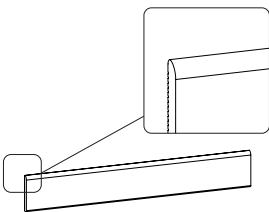

Rodapié
Skirting board

9x60cm 3.5"x23.6"

Coated Top

Cotto Boho



Tabica
Riser

14.5x120cm 3.5"x47.2"

Cotto Boho

Embalaje | Packing

Formatos Formats	piezas / caja pieces / box	m ² / caja sqm / box	kg/caja kg/ box	m ² / palet sqm / pallet	tamaño palet pallet size
90x90 ^R cm 35.4"x35.4"	2	1,6200	32,50	48,60	106x95x74cm
9x60cm 3.5"x23.6"	10	-	15,36	-	110x95x96cm
Rodapié Skirting board					
14.5x120cm 3.5"x47.2"	6	-	22,20	-	125x110x90cm
Tabica Riser					

Colores junta recomendados | Recommended joint colours

Cotto Boho
Mapei 132 Beige 2000
Kerakoll 21 Fugabella
Litokol Ivory 4
SikaCeram Visón

Peldaños | Steps

Peldaño recto | Recto step

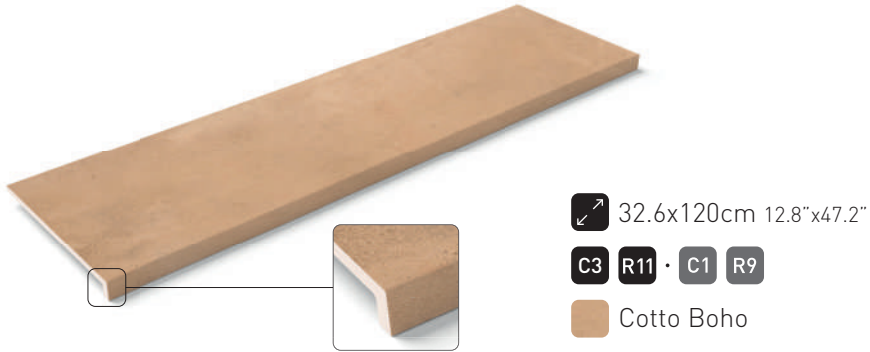

Peldaño recto tapa | Recto step corner





AMAZONIA MIEL

Amazonia

Colección
Collection

Amazonia emula la madera de roble blanco. Sus vetas y nudos distintivos recorren la superficie de la madera, aportando una textura atractiva con carácter y versatilidad, permitiendo que se adapte tanto a ambientes modernos como a estilos más tradicionales que buscan la perfecta unión entre funcionalidad y belleza natural. Nuestra gama de colores, Miel y Canela, presenta una cautivadora graduación de tonos que va desde matices más pálidos hasta tonos más intensos y oscuros.

Amazonia emulates white oak wood. Its distinctive grain and knots run through the surface of the wood, providing an attractive texture with character and versatility, allowing it to suit both modern environments and more traditional styles that seek the perfect marriage of functionality and natural beauty. Our range of colours, Honey and Cinnamon, presents a captivating gradation of shades ranging from paler hues to deeper, darker tones.

Amazonia Miel

Color | Colour



Amazonia Canela

Color | Colour



Montaje de suelo | Floor simulation

Amazonia Miel



Amazonia Canela



Formatos | Formats



↗ 30x120cm 11.8"x47.2"

C3 R11 · C1 R9 ·

Amazonia Miel

Amazonia Canela



↗ 20x120cm 7.8"x47.2"

C3 R11 · C1 R9 ·

Amazonia Miel

Amazonia Canela

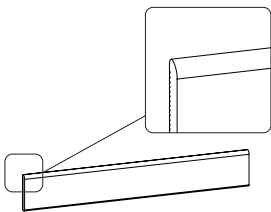

Rodapié
Skirting board

↗ 9x60cm 3.5"x23.6"

Coated Top

Amazonia Miel

Amazonia Canela

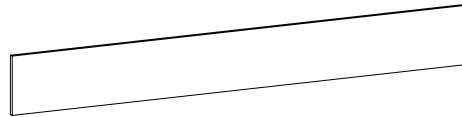

Tabica
Riser

↗ 14.5x120cm 3.5"x47.2"

Amazonia Miel

Amazonia Canela

Embalaje | Packing

Formatos Formats	piezas / caja pieces / box	m ² / caja sqm / box	kg / caja kg / box	m ² / palet sqm / pallet	tamaño palet pallet size
30x120 ^R cm 11.8"x47.2"	4	1,4400	33,37	57,60	120x80x74cm
20x120 ^R cm 7.8"x47.2"	7	1,6800	34,54	73,92	120x80x83cm
9x60cm 3.5"x23.6"	10	-	15,36	-	110x95x96cm
Rodapié Skirting board					
14.5x120cm 3.5"x47.2"	6	-	22,20	-	125x110x90cm
Tabica Riser					

Colores junta recomendados | Recommended joint colours

Amazonia Miel

Mapei 141 Caramel
Kerakoll 09 Caramelo
Litokol Beige 4
SikaCeram Caramelo

Amazonia Canela

Mapei 142 Brown
Kerakoll 11 Marrón
Litokol Brown 1
SikaCeram Caoba

Peldaños | Steps

Peldaño recto | Recto step



Peldaño recto tapa | Recto step corner

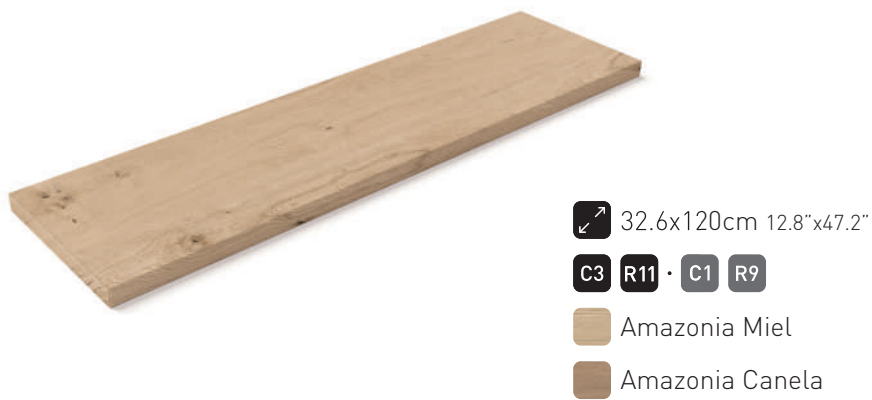

Bordes de piscina | Pool edges

Borde Creta | Creta edge



↗ 32.6x50cm 12.8"x19.7"

C3 R11 · 🚰

Amazonia Miel

Amazonia Canela

Rejillas de drenaje | Drain grates

Rejilla de drenaje RJ25 | Drain grate RJ25



↗ 24,5x50cm 9,6"x19,7"

Desagüe | Drain: >13m³/hora

C3 R11 · 🚰 🌐

Goma para rejilla 9134 incluida
Grate rubber 9134 included

Amazonia Miel

Amazonia Canela

Rejilla de drenaje RJ25 FLEX | Drain grate RJ25 FLEX



↗ 24,5x50cm 9,6"x19,7"

Desagüe | Drain: >30m³/hora

C3 R11 · 🚰 🌐

Goma para rejilla 9134 incluida
Grate rubber 9134 included

Amazonia Miel

Amazonia Canela

Goma para rejilla 9710 | Grate rubber 9710





Goma para rejilla 9134 | Grate rubber 9134



Piezas de terminación | Trims



Media caña exterior
Outer trims



-  4.5x50cm 1.8"x19.7"
- C3 R11** • Ref. MDCA E000
-  Amazonia Miel
-  Amazonia Canela



Escocia cantonera exterior
Scotch external corner



-  4.5x4.5cm 1.8"x1.8"
- C3 R11** • Ref. MDCA EE00
-  Amazonia Miel
-  Amazonia Canela



Esquina cantonera exterior
Outer angle corner



-  6.5x6.5cm 2.6"x2.6"
- C3 R11** • Ref. MDCA AE00
-  Amazonia Miel
-  Amazonia Canela



Media caña interior
Inner trims



-  5.5x50cm 2.2"x19.7"
- C3 R11** • Ref. MDCA I000
-  Amazonia Miel
-  Amazonia Canela



Escocia cantonera interior
Scotch inner corner



-  5.5x5.5cm 2.2"x2.2"
- C3 R11** • Ref. MDCA EI00
-  Amazonia Miel
-  Amazonia Canela



Esquina cantonera interior
Inner angle corner



-  6.5x6.5cm 2.6"x2.6"
- C3 R11** • Ref. MDCA AI00
-  Amazonia Miel
-  Amazonia Canela

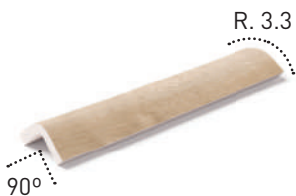

Cantonera transición exterior
External transition corner

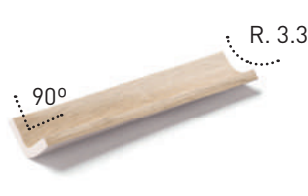

-  4.5x25cm 1.8"x9.8"
- C3 R11** • Ref. MDCA CE00
-  Amazonia Miel
-  Amazonia Canela

Cantonera transición interior
Inner transition corner



-  5.5x25cm 2.2"x9.8"
- C3 R11** • Ref. MDCA CI00
-  Amazonia Miel
-  Amazonia Canela

*Información detallada sobre las piezas de terminación en las páginas 212 y 213.
*Detailed information about trims pieces in pages 212 and 213.



AMAZONIA CANELA



TROPIC AGUAMARINA

Tropic

Colección
Collection

La colección Tropic surge de la fusión de diferentes rocas volcánicas sumada a piedras de una alta destonificación para conseguir un concepto de elevada variedad gráfica y cromática, logrando un resultado vistoso y espectacular. El tono Turqueta va desde los verdes más oscuros e intensos a los más claros y brillantes, con toques de tonos minerales como los rojizos y ocre. El tono Aguamarina nos vira a tonos azulados de igual expresión y potencia visual. Ambos idóneos en grandes proyectos de piscina con su alta propuesta decorativa.

The Tropic collection arises from the fusion of different volcanic rocks added to stones of high detonation to achieve a concept of high graphic and chromatic variety, achieving an eye-catching and spectacular result. The Turqueta tone ranges from the darkest and most intense greens to the lightest and brightest, with touches of mineral tones such as reddish and ochre. The Aquamarine shade veers towards bluish tones of equal expression and visual power. Both are ideal for large swimming pool projects with their high decorative proposal.

Tropic Turqueta

Color | Colour

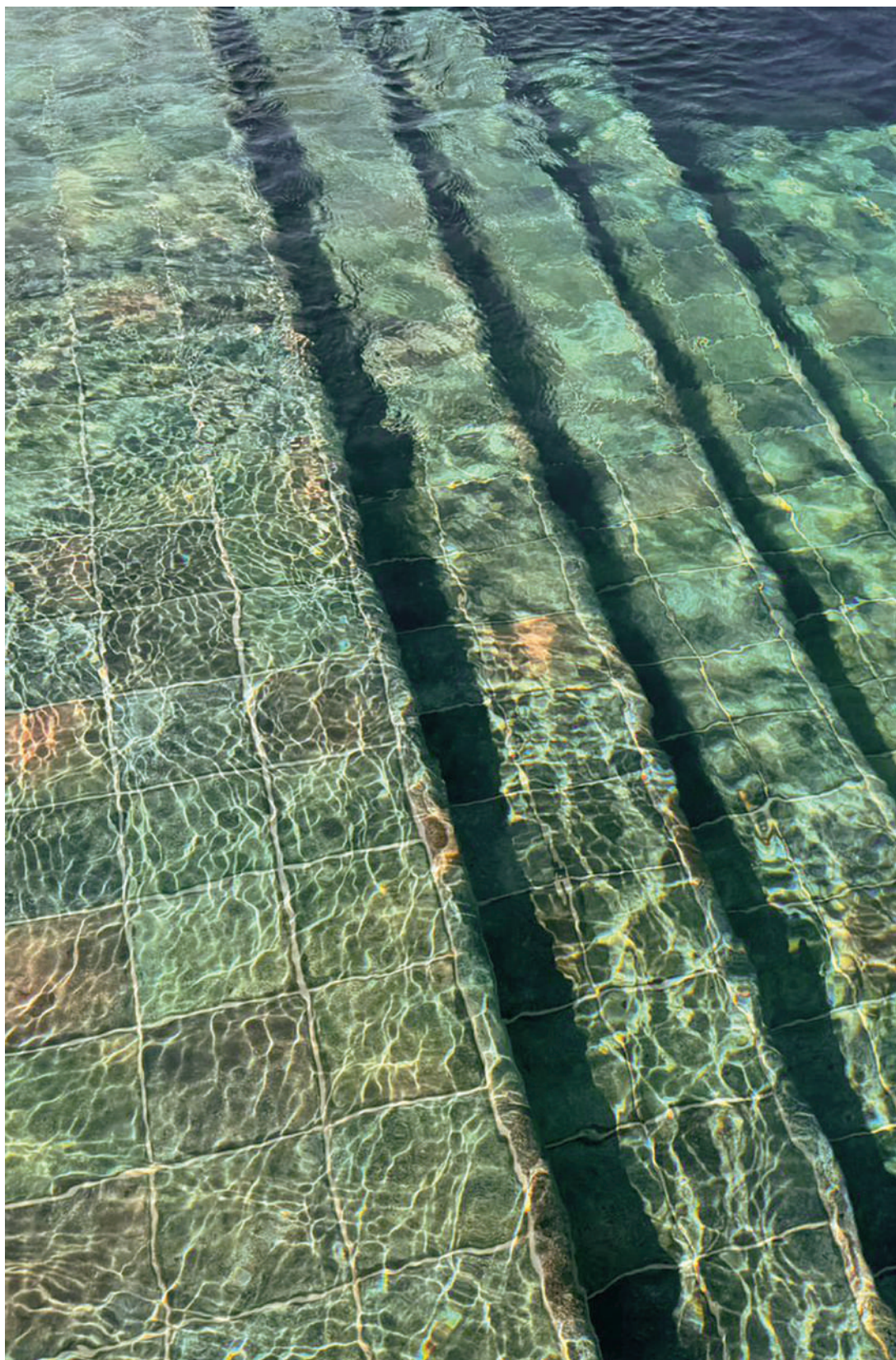

Tropic Aguamarina

Color | Colour

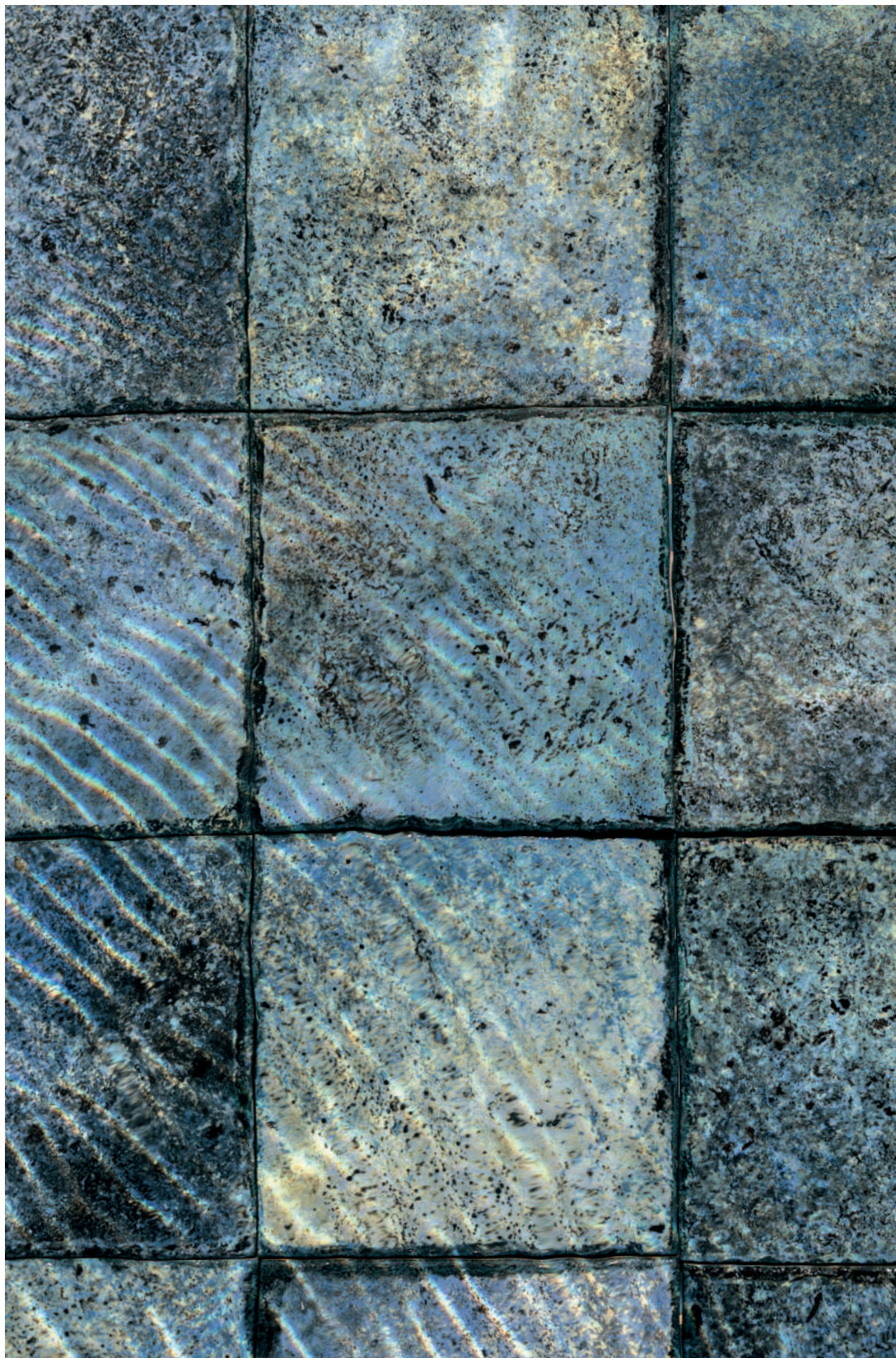

Montaje de suelo | Floor simulation

Tropic Turqueta



C3 R11

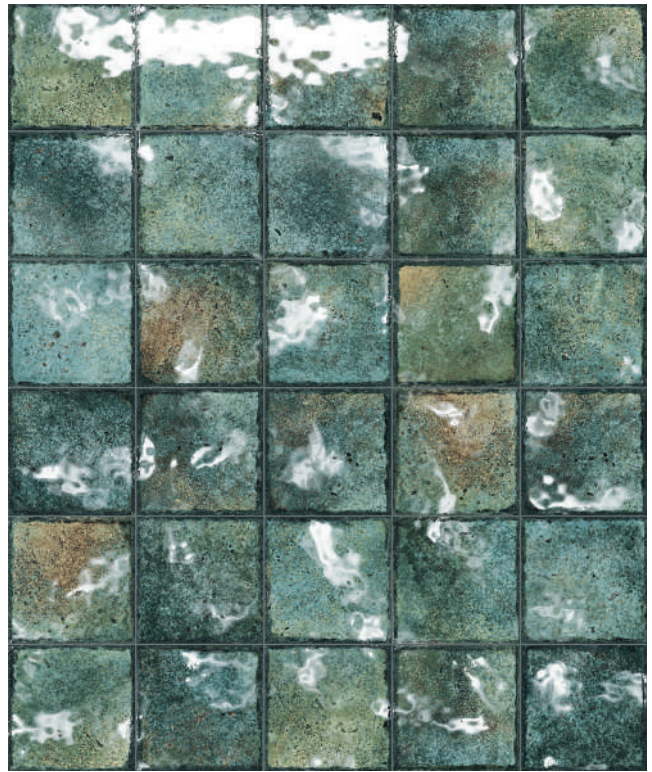

C1 R9

Tropic Aguamarina



C3 R11

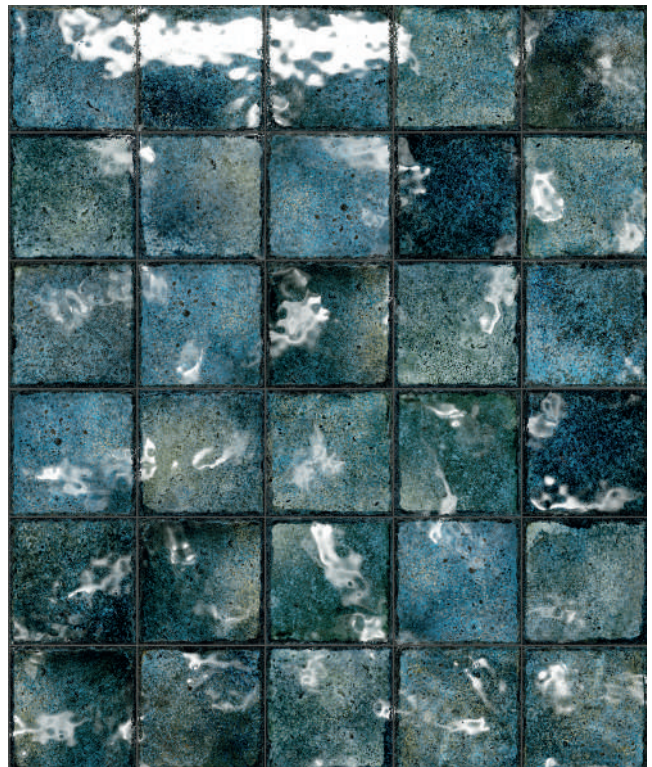

C1 R9

Formatos | Formats



 14.7x14.7cm 5.7"x5.7"

C3 **R11** · **C1** **R9**

 Tropic Turqueta

 Tropic Aguamarina

Embalaje | Packing

Formatos Formats	piezas / caja pieces / box	m ² / caja sqm / box	kg / caja kg / box	m ² / palet sqm / pallet	tamaño palet pallet size
14.7x14.7cm 5.7"x5.7" OUT	44	0,9508	16,97	76,06	120x80x89cm
14.7x14.7cm 5.7"x5.7" IN	42	0,9076	16,20	72,60	120x80x89cm

Colores junta recomendados | Recommended joint colours

 Tropic Turqueta
Mapei 114 Anthracite
Kerakoll 06 Negro
Litokol Black 1
SikaCeram Antracita

 Tropic Aguamarina
Mapei 114 Anthracite
Kerakoll 06 Negro
Litokol Black 1
SikaCeram Antracita

Piezas de terminación | Trims

Media caña exterior
Outer trims



↗ 4.5x50cm 1.8"x19.7"

C3 **R11** · **C1** **R9** · Ref. MDCA E000

 Tropic Turqueta

 Tropic Aguamarina

Escocia cantonera exterior
Scotch external corner



↗ 4.5x4.5cm 1.8"x1.8"

C3 **R11** · **C1** **R9** · Ref. MDCA EE00

 Tropic Turqueta

 Tropic Aguamarina

Esquina cantonera exterior
Outer angle corner



↗ 6.5x6.5cm 2.6"x2.6"

C3 **R11** · **C1** **R9** · Ref. MDCA AE00

 Tropic Turqueta

 Tropic Aguamarina

Media caña interior
Inner trims



↗ 5.5x50cm 2.2"x19.7"

C3 **R11** · **C1** **R9** · Ref. MDCA I000

 Tropic Turqueta

 Tropic Aguamarina

Escocia cantonera interior
Scotch inner corner



↗ 5.5x5.5cm 2.2"x2.2"

C3 **R11** · **C1** **R9** · Ref. MDCA EI00

 Tropic Turqueta

 Tropic Aguamarina

Esquina cantonera interior
Inner angle corner



↗ 6.5x6.5cm 2.6"x2.6"

C3 **R11** · **C1** **R9** · Ref. MDCA AI00

 Tropic Turqueta

 Tropic Aguamarina

Cantonera transición exterior
External transition corner



↗ 4.5x25cm 1.8"x9.8"

C3 **R11** · **C1** **R9** · Ref. MDCA CE00

 Tropic Turqueta

 Tropic Aguamarina

Cantonera transición interior
Inner transition corner

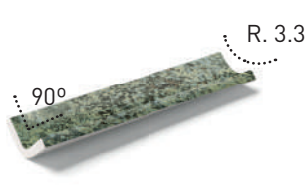

↗ 5.5x25cm 2.2"x9.8"

C3 **R11** · **C1** **R9** · Ref. MDCA CI00

 Tropic Turqueta

 Tropic Aguamarina

*Información detallada sobre las piezas de terminación en las páginas 212 y 213.
*Detailed information about trims pieces in pages 212 and 213.



TROPIC TURQUETA



BALI ZATU

Bali

Colección
Collection

La piedra Bali o Sukabumi de Indonesia, es una variedad de piedra natural, formada por la acumulación de sedimentos. La característica más distintiva de Sukabumi es su color verde esmeralda y su gran diversidad gráfica, con vetas más claras u oscuras, así como áreas con matices más intensos de verdes y verdes-azulados. Las transiciones entre tonos tienden a ser suaves y fluidas, crean una apariencia armoniosa y natural en la piedra. En Cerámica Mayor, incorporamos el nuevo tono GOA a nuestra colección Bali. La nueva variante amplía las opciones de diseño, ofreciendo una estética más rica y sofisticada sin perder la esencia natural de la piedra.

Bali stone, or Sukabumi from Indonesia, is a variety of natural stone, formed by the accumulation of sediments. The most distinctive characteristic of Sukabumi is its emerald green colour and its great graphic diversity, with lighter or darker veins, as well as areas with more intense shades of green and blue-green. The transitions between tones tend to be smooth and fluid, creating a harmonious and natural look to the stone. At Cerámica Mayor we have added the new GOA tone to our Bali collection. This new variant expands the design options, offering a richer and more sophisticated aesthetic without losing the natural essence of the stone.

Bali Zatu

Color | Colour

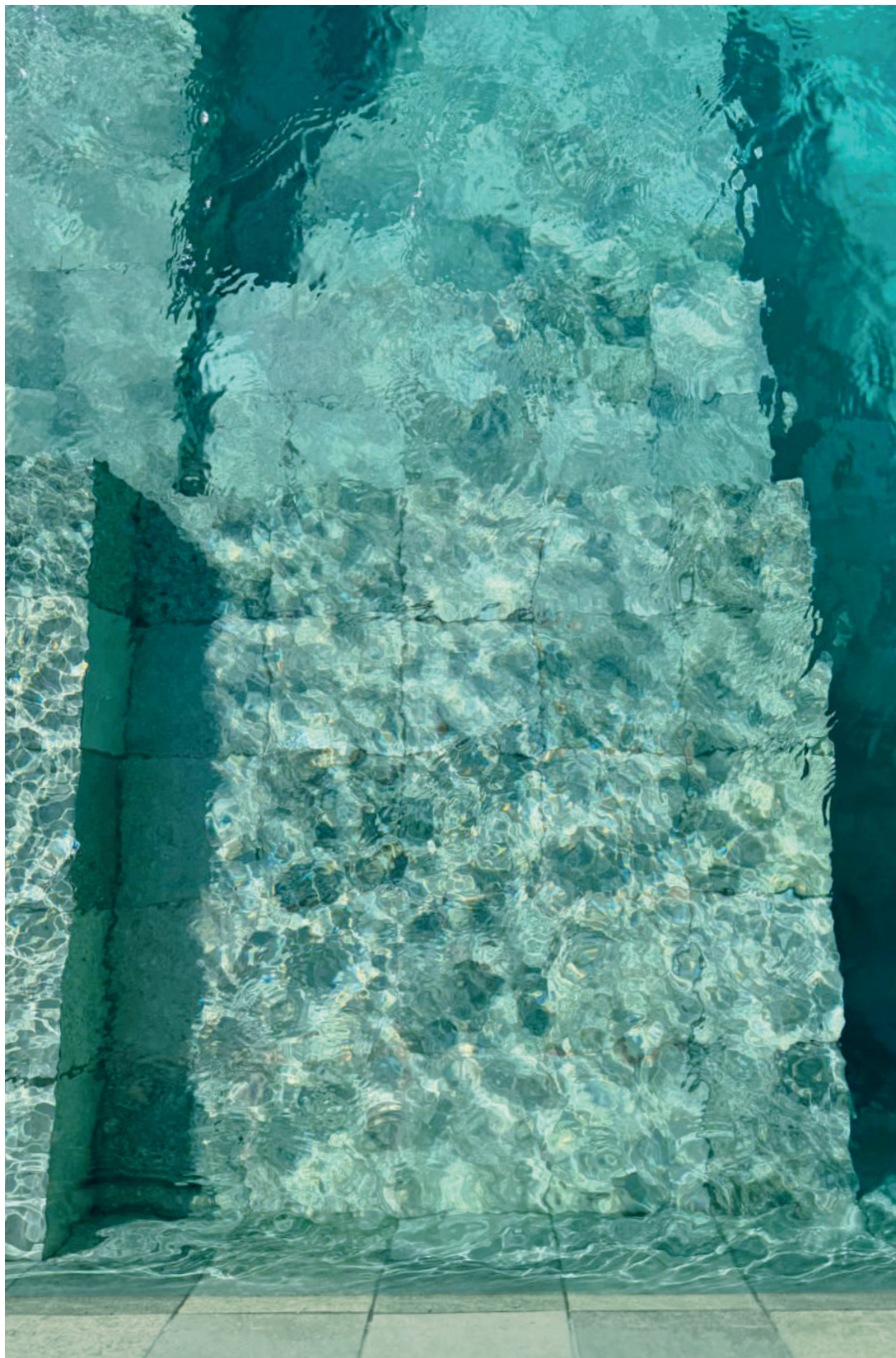

Bali Goa

Color | Colour



Montaje de suelo | Floor simulation

Bali Zatu

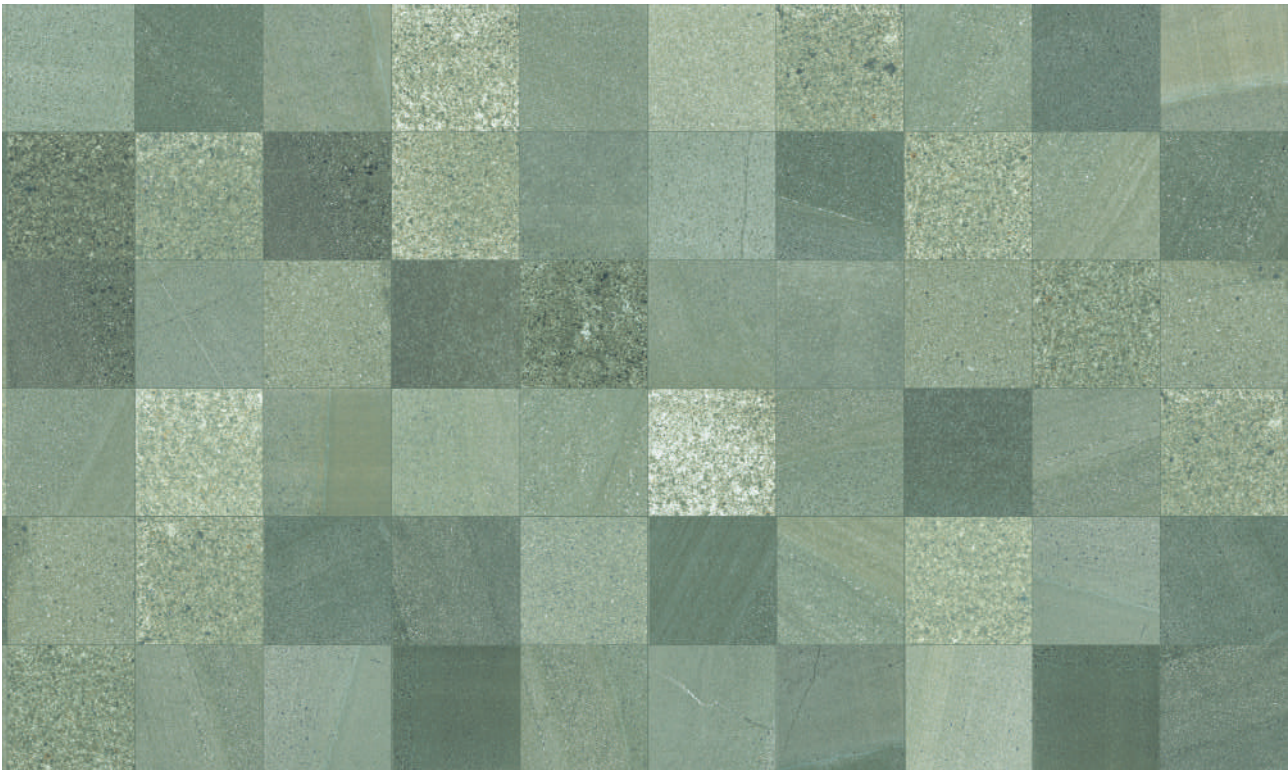

Bali Goa

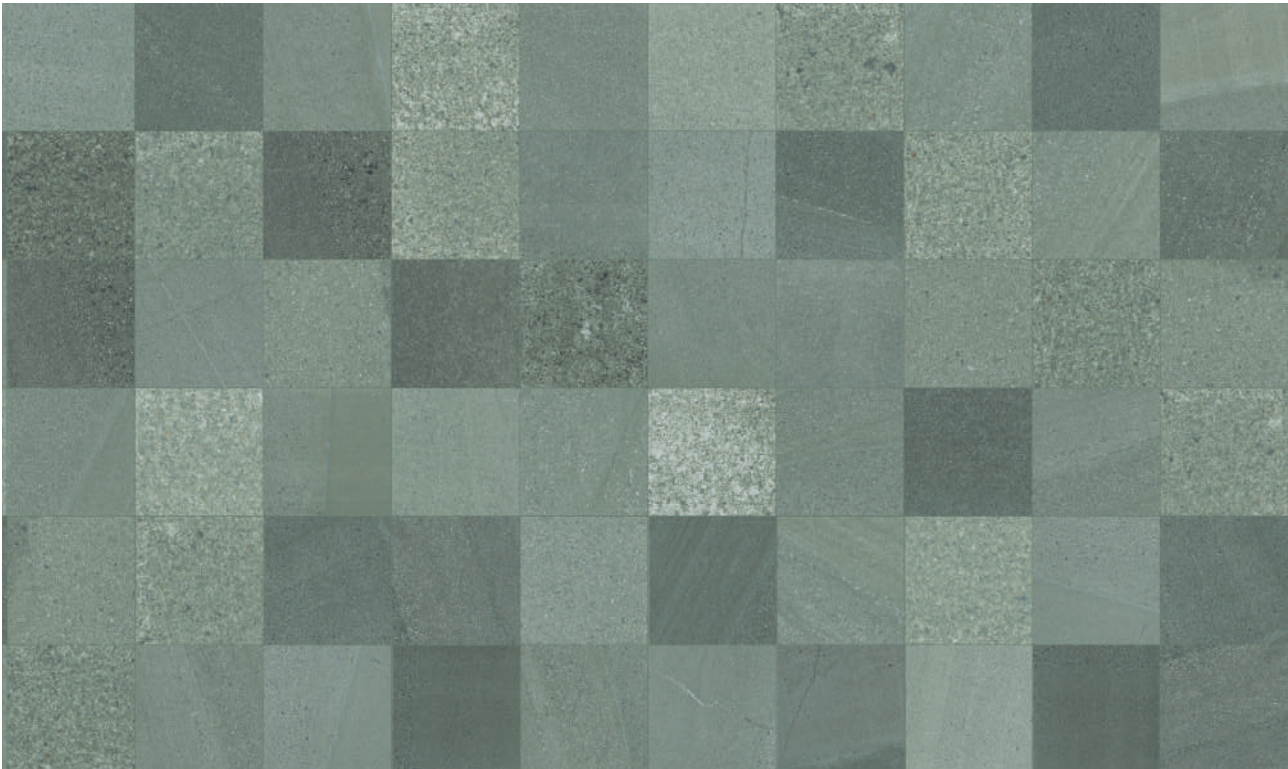

Formatos | Formats



↙ ↘ 14.7x14.7cm 5.7"x5.7"

C3 R11

 Bali Zatu

 Bali Goa



↙ ↘ 30x60cm 11.8"x23.6"

C3 R11 

 Bali Zatu

 Bali Goa

Embalaje | Packing

Formatos Formats	piezas / caja pieces / box	m ² / caja sqm / box	kg / caja kg / box	m ² / palet sqm / pallet	tamaño palet pallet size
14.7x14.7cm 5.7"x5.7" OUT	44	0,9508	16,97	76,06	120x80x89cm
30x60cm 11.8"x23.6"	8	1,4400	27,00	57,60	120x80x74cm

Colores junta recomendados | Recommended joint colours



Bali Zatu

Mapei 180 Mint
Kerakoll 29 Verde Asturias
Litokol Verde Capri 810
SikaCeram Menta



Bali Goa

Mapei 170 Celeste Crocus
Kerakoll 14 Fugabella
Litokol Silver 3
SikaCeram Zafiro

Peldaños | Steps

Peldaño recto | Recto step

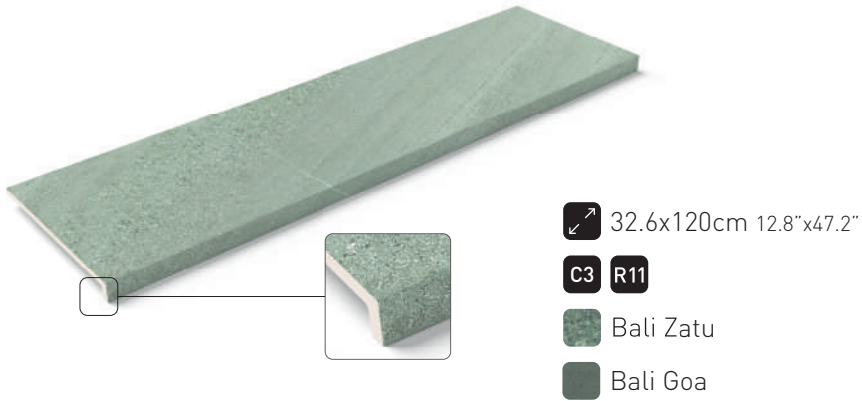

Peldaño recto tapa | Recto step corner



Bordes de piscina | Pool edges

Borde Creta | Creta edge



 32.6x50cm 12.8"x19.7"

C3 **R11** · 

 Bali Zatu

 Bali Goa

Piezas de terminación | Trims

Media caña exterior
Outer trims



-  4.5x50cm 1.8"x19.7"
- C3 R11** • Ref. MDCA E000
-  Bali Zatu
-  Bali Goa

Escocia cantonera exterior
Scotch external corner



-  4.5x4.5cm 1.8"x1.8"
- C3 R11** • Ref. MDCA EE00
-  Bali Zatu



Esquina cantonera exterior
Outer angle corner



-  6.5x6.5cm 2.6"x2.6"
- C3 R11** • Ref. MDCA AE00
-  Bali Zatu



Media caña interior
Inner trims



-  5.5x50cm 2.2"x19.7"
- C3 R11** • Ref. MDCA I000
-  Bali Zatu
-  Bali Goa



Escocia cantonera interior
Scotch inner corner



-  5.5x5.5cm 2.2"x2.2"
- C3 R11** • Ref. MDCA EI00
-  Bali Zatu
-  Bali Goa



Esquina cantonera interior
Inner angle corner



-  6.5x6.5cm 2.6"x2.6"
- C3 R11** • Ref. MDCA AI00
-  Bali Zatu
-  Bali Goa

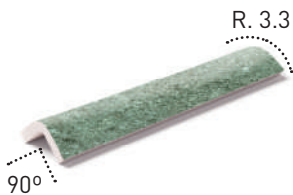

Cantonera transición exterior
External transition corner

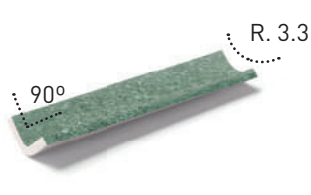

-  4.5x25cm 1.8"x9.8"
- C3 R11** • Ref. MDCA CE00
-  Bali Zatu
-  Bali Goa

Cantonera transición interior
Inner transition corner



-  5.5x25cm 2.2"x9.8"
- C3 R11** • Ref. MDCA CI00
-  Bali Zatu
-  Bali Goa

*Información detallada sobre las piezas de terminación en las páginas 212 y 213.
*Detailed information about trims pieces in pages 212 and 213.



BALI GOA



VOLCANIC LAVA

Volcanic

Colección
Collection

Volcanic está inspirada en el origen de la piedra basáltica, roca que nace de la rápida solidificación de la lava volcánica. Una piedra de característico aspecto oscuro, con gamas de tonos que varían desde el gris oscuro hasta el negro más intenso. Presenta fondos moteados, y textura porosa muy distintiva. Un aspecto que se ha recreado con amplias técnicas y respetuosas con el medio ambiente. Con todas estas características el conjunto crea una atmósfera de elegancia y versatilidad.

Volcanic is inspired by the origin of basalt stone, a rock born from the rapid solidification of volcanic lava. A stone with a characteristic dark appearance, with shades ranging from dark grey to the deepest black. It has mottled backgrounds, and a very distinctive porous texture. A look that has been recreated with extensive and environmentally friendly techniques. With all these features the ensemble creates an atmosphere of elegance and versatility.

Volcanic Lava

Color | Colour



Montaje de suelo | Floor simulation

Volcanic Lava

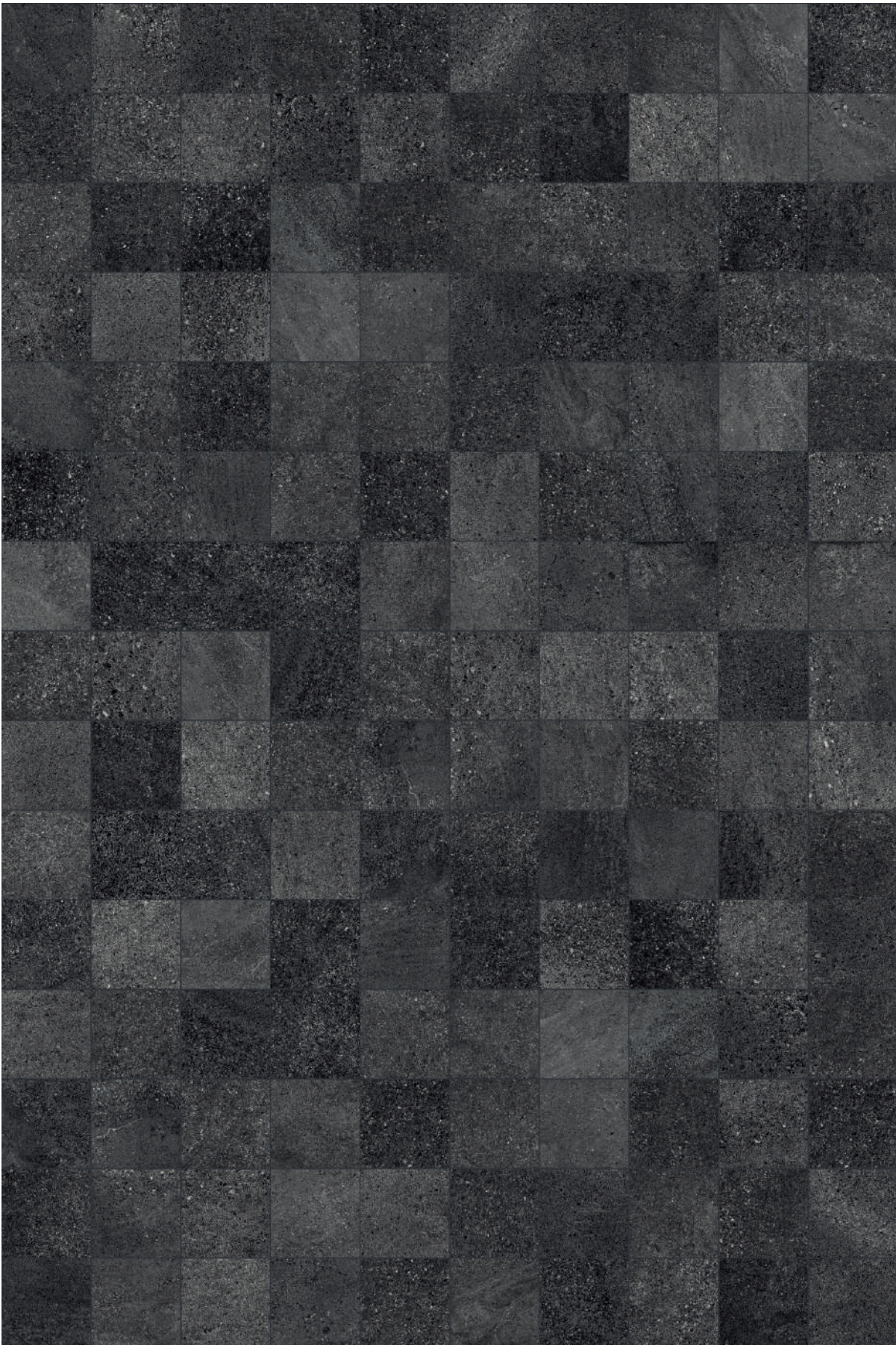

Formatos | Formats



↙ ↘ 14.7x14.7cm 5.7"x5.7"

C3 R11

■ Volcanic Lava



↙ ↘ 30x60cm 11.8"x23.6"

C3 R11 · R

■ Volcanic Lava

Embalaje | Packing

Formatos Formats	piezas / caja pieces / box	m ² / caja sqm / box	kg / caja kg / box	m ² / palet sqm / pallet	tamaño palet pallet size
14.7x14.7cm 5.7"x5.7" OUT	44	0,9508	16,97	76,06	120x80x89cm
30x60 ^R cm 11.8"x23.6"	8	1,4400	27,00	57,60	120x80x74cm

Colores junta recomendados | Recommended joint colours

■ Volcanic Lava

Mapei 114 Anthracite

Kerakoll 06 Negro

Litokol Black 1

SikaCeram Antracita

Peldaños | Steps

Peldaño recto | Recto step



Peldaño completo | Recto step corner



Bordes de piscina | Pool edges

Borde Creta | Creta edge



Piezas de terminación | Trims

Media caña exterior
Outer trims



↗ 4.5x50cm 1.8"x19.7"
C3 R11 • Ref. MDCA E000
 Volcanic Lava

Escocia cantonera exterior
Scoth external corner



↗ 4.5x4.5cm 1.8"x1.8"
C3 R11 • Ref. MDCA EE00
 Volcanic Lava

Esquina cantonera exterior
Outer angle corner



↗ 6.5x6.5cm 2.6"x2.6"
C3 R11 • Ref. MDCA AE00
 Volcanic Lava

Media caña interior
Inner trims



↗ 5.5x50cm 2.2"x19.7"
C3 R11 • Ref. MDCA I000
 Volcanic Lava

Escocia cantonera interior
Scoth inner corner



↗ 5.5x5.5cm 2.2"x2.2"
C3 R11 • Ref. MDCA EI00
 Volcanic Lava

Esquina cantonera interior
Inner angle corner



↗ 6.5x6.5cm 2.6"x2.6"
C3 R11 • Ref. MDCA AI00
 Volcanic Lava

Cantonera transición exterior
External transition corner

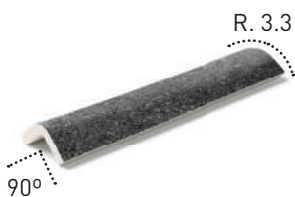

↗ 4.5x25cm 1.8"x9.8"
C3 R11 • Ref. MDCA CE00
 Volcanic Lava

Cantonera transición interior
Inner transition corner

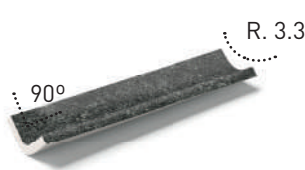

↗ 5.5x25cm 2.2"x9.8"
C3 R11 • Ref. MDCA CI00
 Volcanic Lava

*Información detallada sobre las piezas de terminación en las páginas 212 y 213.
 *Detailed information about trims pieces in pages 212 and 213.



VOLCANIC LAVA

Gres porcelánico de 20mm
20mm porcelain tiles

20mm

Espesor | Thickness

Los pavimentos cerámicos de 20MM de espesor ofrecen una solución robusta y segura, permitiendo su empleo en una amplia variedad de aplicaciones. Presentan la combinación perfecta entre resistencia, durabilidad y versatilidad.

Con un grosor de 20MM, estos suelos cerámicos son capaces de soportar cargas pesadas y resistir el desgaste diario en entornos de alto tránsito, lo que los hace ideales no solo para uso privado, sino también para áreas comerciales, públicas y residenciales donde se requiera una mayor resistencia a la abrasión y al impacto.

20mm thick ceramic floor tiles offer a robust and safe solution, allowing them to be used in a wide variety of applications. They offer the perfect combination of strength, durability and versatility.

With a thickness of 20mm, this ceramic flooring is able to withstand heavy loads and resist daily wear and tear in high traffic environments, making them ideal not only for private use, but also for commercial, public and residential areas where greater resistance to abrasion and impact is required.

60X120X2CM 23.6"x47.2"x0.78"

COLORES DISPONIBLES
AVAILABLE COLOURS



Crosscut Petra

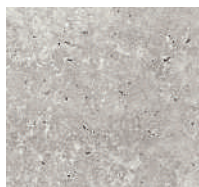

Crosscut Cloud



Stromboli Light

90X90X2CM 35.4"x35.4"x0.78"

COLORES DISPONIBLES
AVAILABLE COLOURS



Savoy Moon



Savoy Desert



Savoy Land



Salem Clar



Aplicación en terrazas
Terrace application



Aplicación en piscinas
Pool application



Aplicación en jardines
Garden application



Aplicación en parking
Parking application



Aplicación en parques
Application in parks



Aplicación en establecimientos
de playas
Application in beach
establishments

Este pavimento está diseñado para soportar condiciones adversas, como la constante exposición al sol, a las nevadas o los choques térmicos. Mantiene intacta su apariencia en el tiempo, presentando una baja porosidad, así como una baja absorción de agua. Así, es resistente a zonas constantemente húmedas como las piscinas, además de ser ignífugo, resistente a los químicos y antislip.

This flooring is designed to withstand adverse conditions, such as constant exposure to the sun, snowfall, or thermal shocks. It maintains its appearance intact over time, with low porosity and low water absorption. Thus, it is resistant to constantly wet areas, such as swimming pools, as well as being flame retardant, chemical resistant and anti-slip.



20mm

Espesor | Thickness

El gres porcelánico de 20MM de Cerámica Mayor se desarrolla exclusivamente en acabado para antideslizante para exteriores C3 y puede colocarse en diferentes tipos de suelo. El formato 20MM destaca por la facilidad en la instalación, destacando el uso del pavimento sobre plots por sus múltiples ventajas. El material perfecto para ejecutar cualquier proyecto que necesite el plus de antideslizamiento con un acabado y resistencia excepcional.

Cerámica Mayor's 20MM porcelain stoneware is developed exclusively in the C3 non-slip finish for outdoor use and can be laid on different types of floors. The 20MM format stands out for its ease of installation, highlighting the use of paving on plots for its many advantages. The perfect material for any project that needs the added bonus of anti-slip with an exceptional finish and resistance.



Sobre grava o arena
On gravel or sand



Sobre césped
On grass

Ventajas

Advantages

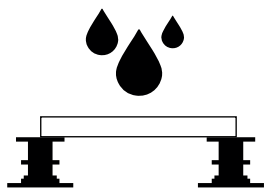

Drenaje agua fluvial y limpieza
Rainwater drainage and cleaning

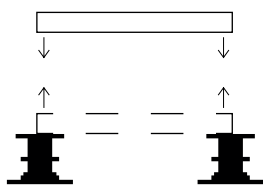

Instalación rápida
Quick installation

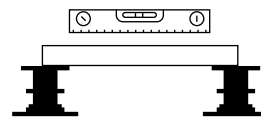

Acabado nivelado
Leveled finish

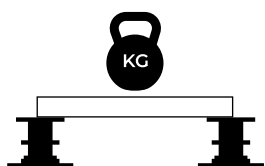

Resistencia peso del mobiliario y tráfico personal
Resistance to furniture and personal traffic

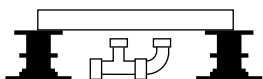

Fácil acceso al soporte y instalaciones ocultas
Easy access to support and concealed installations

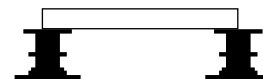
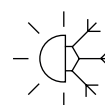

Excelente aislamiento térmico
Improved thermal insulation



Sobre plots
On plots

POOL

SOLUTIONS

Sistema desbordante

Overflow system

Este es uno de los sistemas que mayor continuidad consigue y se ha convertido en un diseño de piscina distintivo y visualmente atractivo que permite que el agua desbordante sea recirculada eficientemente a través de las rejillas de drenaje con canaleta que bordean el vaso. Estas piscinas son modernas y elegantes, adaptándose a estilos arquitectónicos contemporáneos y consiguiendo la integración en el entorno.

This is one of the systems that achieves the greatest continuity and has become a distinctive and visually appealing pool design that allows overflowing water to be efficiently recirculated through the gutter drainage grilles that line the pool. These pools are modern and elegant, adapting to contemporary architectural styles and blending into their surroundings.

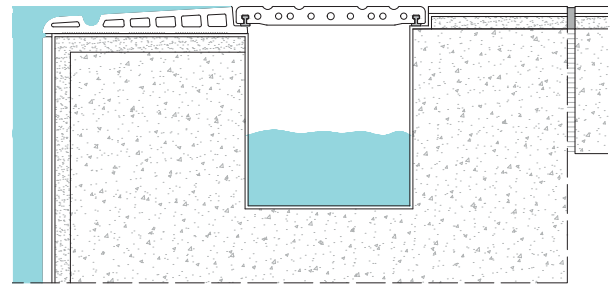

Crosscut Cloud, Tropic Turqueta

CORONACIÓN CON BORDE DESBORDANTE Y REJILLA DE DRENAJE

Cerámica Mayor ofrece 3 tipos de borde desbordante: Creta, Maui y Aruba, todos combinables con los 5 tipos de rejillas de drenaje: RJ20, RJ20 FLEX, RJ25, RJ25 FLEX y RJ25 INV.

POOL COPING WITH OVERFLOW EDGE AND DRAIN GRATE

Cerámica Mayor offers 3 types of overflow edge: Creta, Maui and Aruba, all combinable with the 5 types of drain grates: RJ20, RJ20 FLEX, RJ25, RJ25 FLEX and RJ25 INV.

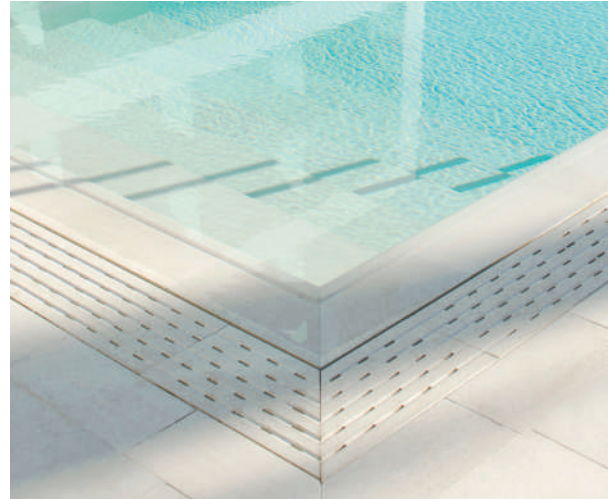

Stromboli Light



Cements Smoke

Sistema Infinity

Infinity System

Haciendo desaparecer el borde en el horizonte con su efecto "sin fin", las piscinas infinity se distinguen debido a su perfecta integración en el paisaje circundante, creando un efecto visual impresionante. Con un diseño arquitectónico moderno, estas piscinas de gres porcelánico guían el flujo del agua hacia el canal situado en la zona infinity manteniendo la calidad del agua y el constante desbordamiento de esta.

Making the edge disappear into the horizon with their 'endless' effect, infinity pools are distinguished by their perfect integration into the surrounding landscape, creating a stunning visual effect. With a modern architectural design, these porcelain stoneware pools guide the flow of water into the channel located in the infinity zone while maintaining the quality of the water and the constant overflow of the water.

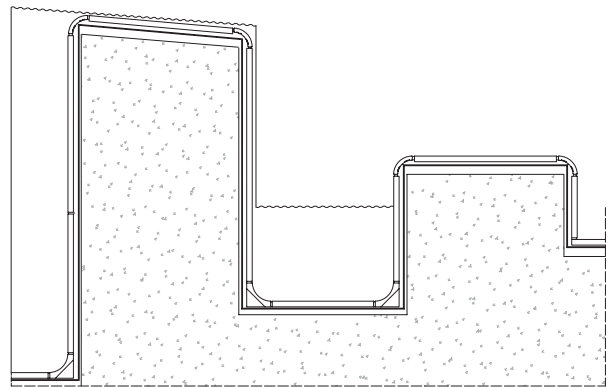

Salem Clar

CORONACIÓN CON MEDIAS CAÑAS

Actualmente Cerámica Mayor ofrece dos tipos de coronación para piscina infinity y las medias cañas son una de ellas, pudiéndose colocar en la zona desbordante ofreciendo un acabado continuo generado por las piezas MDCA I000 y MDCA E000.

POOL COPING WITH TrimsS

Cerámica Mayor currently offers two types of coping for infinity pools and trimss are one of them, which can be placed in the overflow area offering a continuous finish generated by the MDCA I000 and MDCA E000 pieces.



Salem Clar

CORONACIÓN CON BORDE CRETA

La segunda forma de crear el efecto “sin fin” en la piscina es utilizando el borde Creta en la zona de la coronación y desbordamiento de la piscina, empleando así una única pieza para dar solución de manera sencilla a este tipo de piscinas.

POOL COPING WITH CRETA EDGE

The second way to create the “endless” effect is to use the Creta edge in the pool coping and its overflow area, thus using a single piece to provide a simple solution for this type of pool.

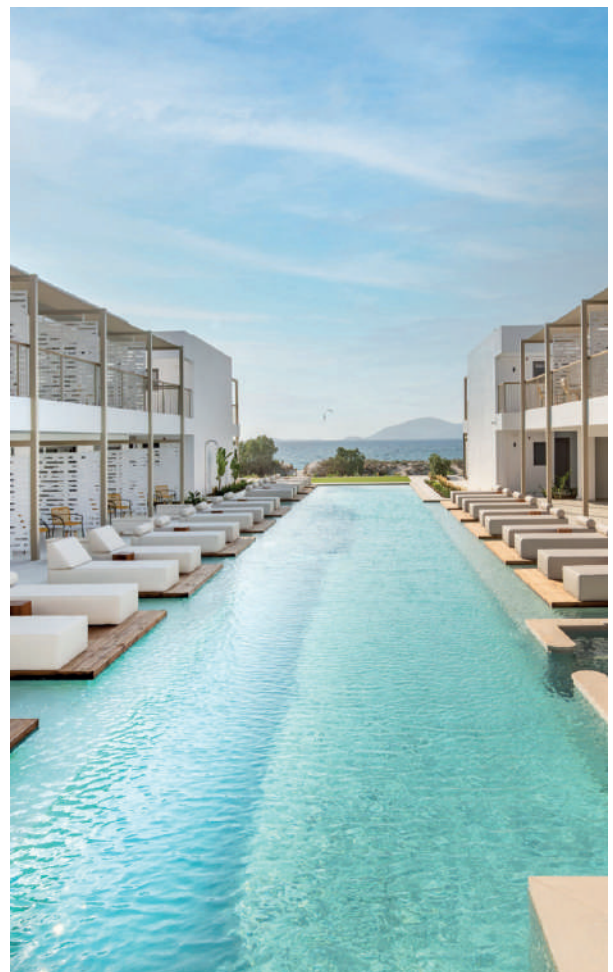

Cements Warm

Sistema Skimmer

Skimmer system

Las piscinas skimmer se mantienen atemporales en el tiempo, siendo el estilo más clásico de los tres. Gracias a su sistema de filtrado, el skimmer recoge el agua y elimina los residuos que flotan en la superficie de esta manteniéndola libre de impurezas. Además, mantiene la integración entre el interior de la piscina y el exterior pudiéndose utilizar el mismo color para ambos, logrando así un espacio unificado y moderno.

Skimmer pools remain timeless over time, being the most classic of the three styles. Thanks to its filtering system, the skimmer collects the water and eliminates the waste that floats on the surface, keeping it free of impurities. In addition, it maintains the integration between the interior of the pool and the exterior, and the same colour can be used for both, thus achieving a unified and modern space.

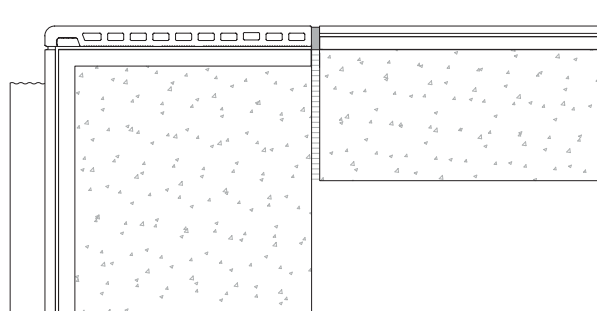

Stromboli Light



Crosscut Petra

CORONACIÓN CON BORDE DE PISCINA SKIMMER

Aunque es uno de los sistemas más clásicos, el sistema skimmer se mantiene atemporal y Cerámica Mayor ha creado 2 soluciones idóneas para su coronación, los bordes Creta y Samoa, tanto para piscinas reformadas como de nueva obra.

POOL COPING WITH SKIMMER POOL EDGE

Although it is one of the most classic systems, the skimmer system remains timeless. Cerámica Mayor has created 2 ideal solutions for its coping, the Creta edge and Samoa edge, for both refurbished and newly built pools.



Bali Zatu | Crosscut Petra

CORONACIÓN CON PELDAÑO

Otra de las maneras para coronar una piscina skimmer es con la pieza de peldaño recto cuya geometría permite resolver el ángulo recto generado entre la terraza y la piscina, permitiendo crear piscinas de aspecto moderno y minimalista.

POOL COPING WITH RECTO STEP

Another way for coping a skimmer pool is with the straight step whose geometry allows to solve the right angle generated between the terrace and the pool, allowing to create pools with a modern and minimalist look.

Interior de la piscina

Inside the swimming pool

El gres porcelánico es el material perfecto para el revestimiento interior de una piscina por su resistencia, versatilidad y durabilidad. Permite integrar distintas soluciones que añaden valor al proyecto y mejoran la funcionalidad y la estética. Una de estas soluciones técnicas son las medias cañas, que permiten la continuidad visual, el acabado antideslizante, la seguridad y la correcta limpieza en el interior de la piscina.

Porcelain tile is the perfect material for the interior lining of a swimming pool due to its resistance, versatility and durability. It allows the integration of different solutions that add value to the project and improve functionality and aesthetics. One of these technical solutions are trimss, which allow for visual continuity, a non-slip finish, safety and proper cleaning inside the pool.



Cupira Marengo

SOLUCIÓN CON MEDIAS CAÑAS PARA EL INTERIOR DEL VASO DE LA PISCINA

Cerámica Mayor ofrece 8 tipos distintos de piezas especiales de media caña para el revestimiento interior de la piscina, evitando así los ángulos rectos y ofreciendo la continuidad deseada en el mismo color que el resto de la piscina.

SOLUTION WITH Trims FOR THE INSIDE OF THE POOL BASIN

Cerámica Mayor offers 8 different types of special trimss for the interior lining of the pool, avoiding right angles and offering the desired continuity in the same colour as the rest of the pool.



Crosscut Petra



Stromboli Light

Sistema Block 25

Block 25 System

MONTAJE DEL SISTEMA BLOCK 25 | ASSEMBLY OF THE BLOCK 25 SYSTEM

El sistema Block 25 de Cerámica Mayor se compone de un conjunto de bloques de hormigón prefabricado hidrófugo cuyo objetivo principal es dejar preparada la superficie de coronación de la piscina para recibir las piezas cerámicas.

The Block 25 system by Cerámica Mayor consists of a set of prefabricated water-repellent concrete blocks whose main purpose is to prepare the pool coping surface to receive the ceramic pieces.

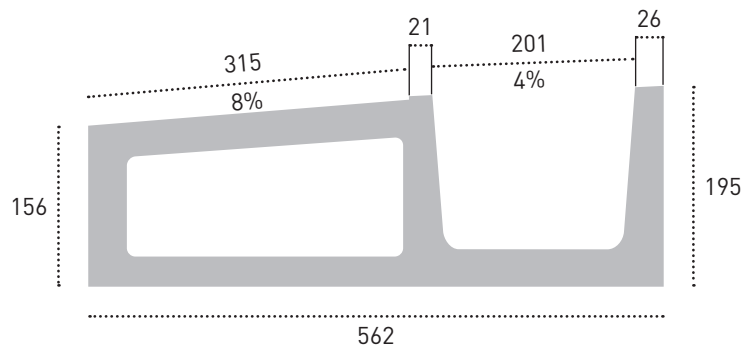

Ref. SISTEMA BLOCK 25

Este sistema permite ejecutar con rapidez cualquier tipo de proyecto de piscina, desde las más pequeñas en viviendas privadas a las más grandes en lujosos hoteles.

This system allows any type of swimming pool project to be carried out quickly, from the smallest in private homes to the largest in luxury hotels.

Block 25 se integra perfectamente con nuestros bordes de piscina Creta y Maui y nuestras rejillas de drenaje cerámicas de 25cm de anchura, como lo son las rejillas RJ25 y RJ25 FLEX.

Block 25 integrates perfectly with our Creta and Maui pool edges and our 25cm wide ceramic drainage gratings, such as RJ25 and RJ25 FLEX.

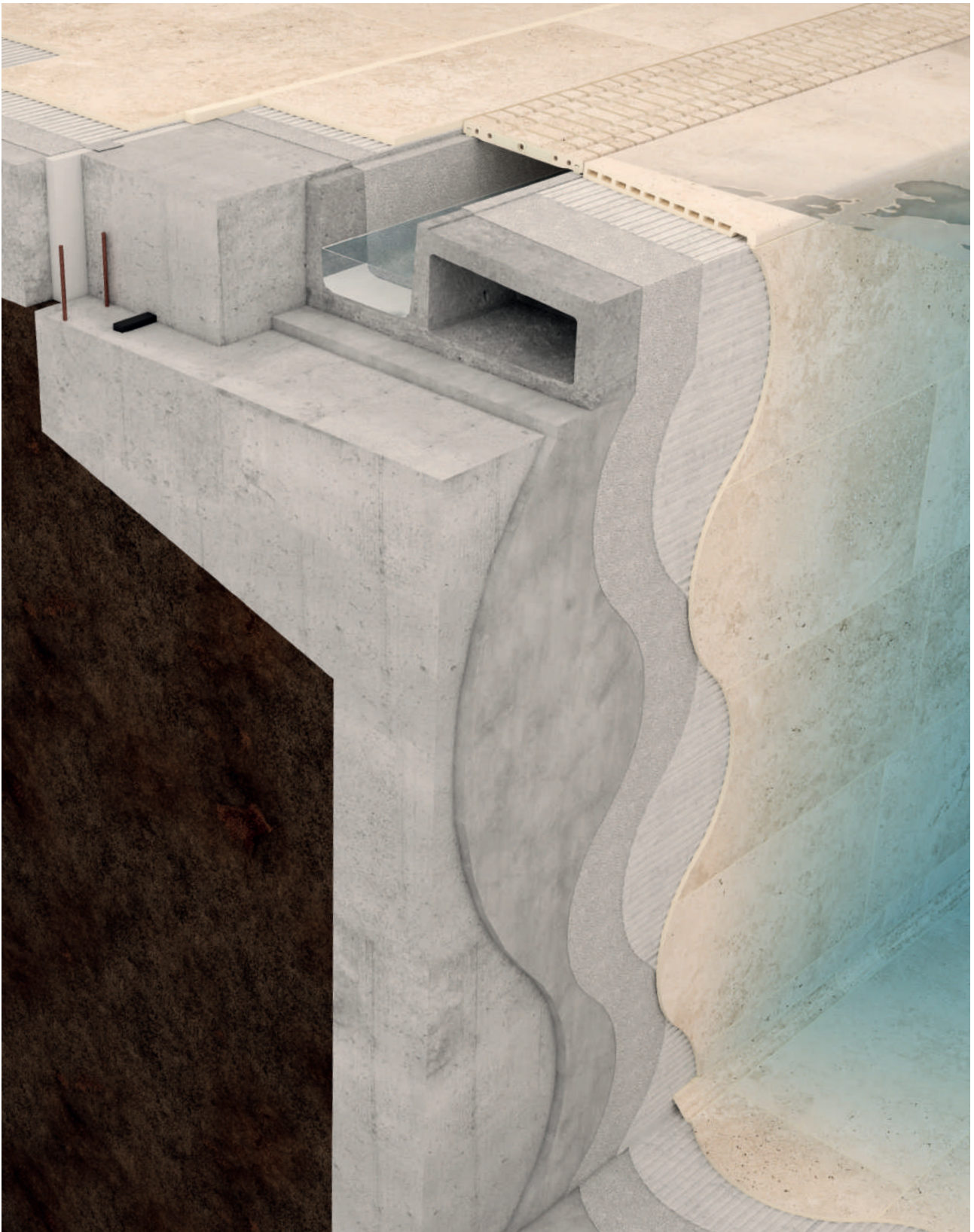

Escanea este QR y descubre las ventajas de nuestro sistema constructivo de colocación.
Scan this QR and discover the advantages of our constructive installation system.

Ventajas Sistema Block 25

Advantages Block 25 System

MONTAJE DEL SISTEMA BLOCK 25 | ASSEMBLY OF THE BLOCK 25 SYSTEM

Los bloques de hormigón para canales de piscinas son una solución práctica, resistente y eficiente, con múltiples ventajas.

Concrete blocks for swimming pool channels are a practical, resistant and efficient solution with many advantages.



Facilidad de instalación

Su diseño permite colocarlos rápidamente y con precisión, optimizando tiempos y logrando un acabado uniforme.

Their design allows them to be fitted quickly and accurately, optimising time and achieving a uniform finish.



Alta resistencia

Ideales para entornos de piscinas, resisten humedad, temperaturas extremas y desgaste.

Ideal for swimming pool environments, they resist moisture, extreme temperatures and wear and tear.



Ahorro de tiempo y costos

Combinan funcionalidad y facilidad de instalación, reduciendo esfuerzos y costos en la obra.

They combine functionality and ease of installation, reducing efforts and costs on site.



Base estable para cerámica

Ofrecen una superficie plana que facilita la instalación de piezas cerámicas, garantizando durabilidad y estética.

They offer a flat surface that facilitates the installation of ceramic tiles, guaranteeing durability and aesthetics.



Adaptabilidad

Se ajustan a cualquier diseño o necesidad del proyecto. La elección perfecta para construir una piscina funcional, resistente y con un acabado impecable.

They fit any design or project needs. The perfect choice for building a functional, resistant pool with an impeccable finish.

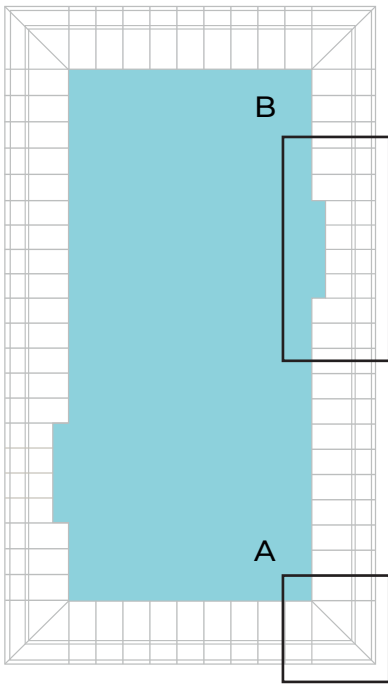

A

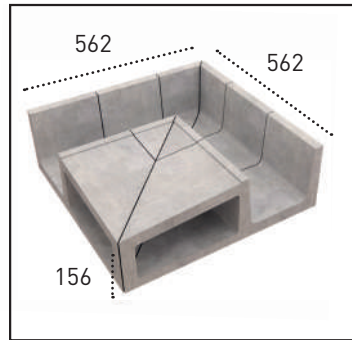

ESQUINA EXTERIOR
Ref. SISTEMA BLOCK 25 MACIZO

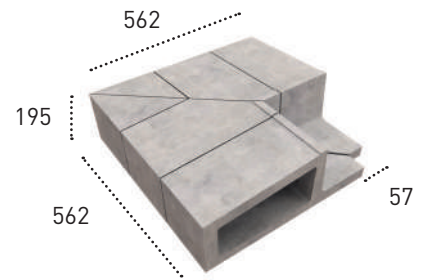

ESQUINA INTERIOR
Ref. SISTEMA BLOCK EI 25

B



Ubicación de los diferentes tipos de bloque en zona de acceso
Location of the different block types in access area



1 PIEZA BLOCK 25 (STANDARD)
Ref. SISTEMA BLOCK 25



2 PIEZA BLOCK 25 MACIZO
Ref. SISTEMA BLOCK 25 MACIZO

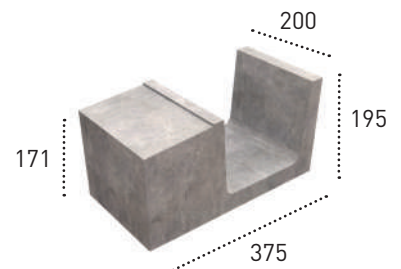

3 PIEZA BLOCK 25 MACIZA CORTADA
Ref. SISTEMA BLOCK 25 MEDIO MACIZO

Bordes, rejillas y medias cañas para piscina
Edges, drain grates and trims for swimming
pools

Creta

Borde de piscina | Pool edge

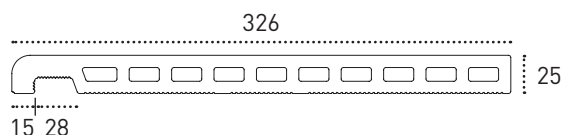
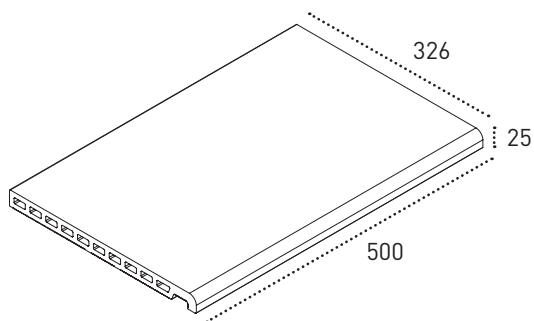

32.6x50cm 12.8"x19.7"

C3 R11 • Ref. BPCR 0000

5%

3 caras | 3 sides

COLORES DISPONIBLES | AVAILABLE COLOURS



SOLUCIÓN CURVA | CURVED SOLUTION

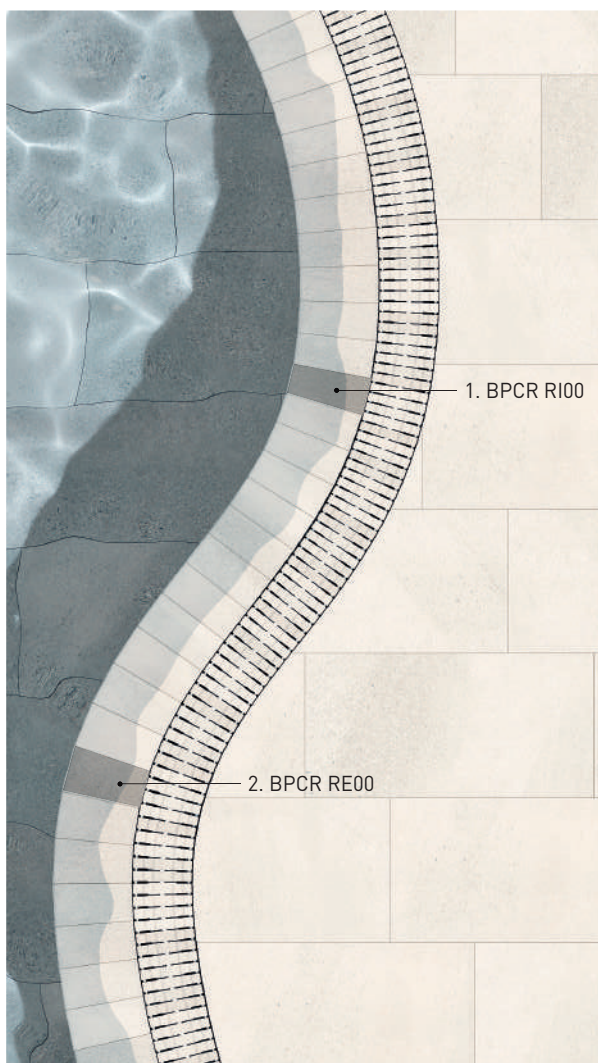

BORDE CURVO CRETA CRETA CURVED EDGE

1. BPCR RI00
2. BPCR RE00

Compatible con las rejillas RJ25, RJ25 FLEX, RJ20, RJ20 FLEX y RJ25 INV
Can be used with drain grates RJ25, RJ25 FLEX, RJ20, RJ20 FLEX and RJ25 INV

SOLUCIÓN ESQUINA | CORNER SOLUTION

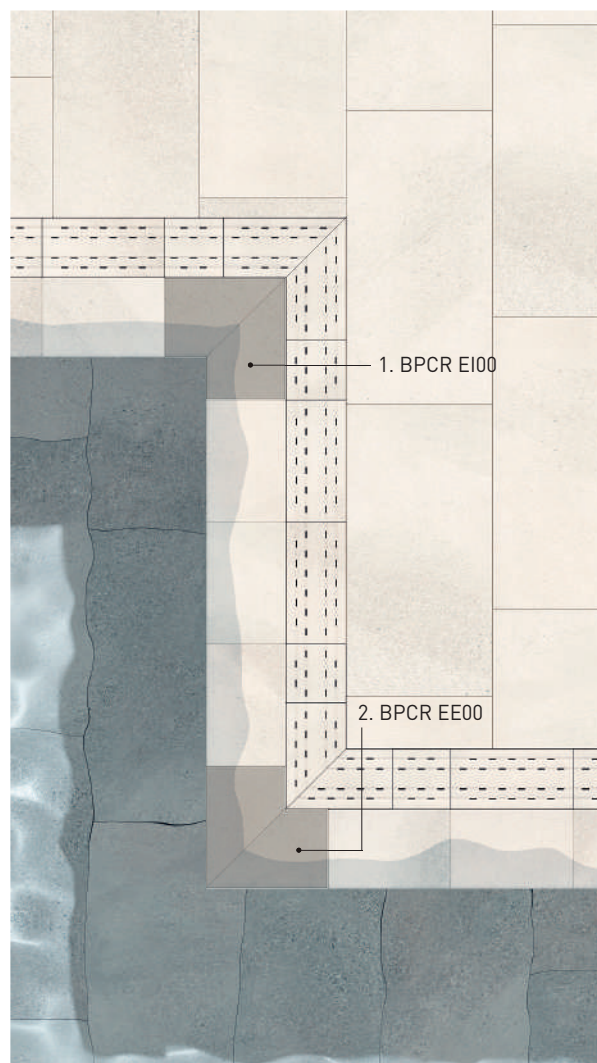

PACK ESQUINA BORDE CRETA (2pcs) CRETA EDGE CORNER PACK (2pcs)

1. BPCR EI00 32.6x50cm 12.8"x19.7"
2. BPCR EE00 32.6x50cm 12.8"x19.7"

Compatible con las rejillas RJ25, RJ25 FLEX, RJ20, RJ20 FLEX y RJ25 INV
Can be used with drain grates RJ25, RJ25 FLEX, RJ20, RJ20 FLEX and RJ25 INV

INFORMACIÓN TÉCNICA | TECHNICAL INFORMATION

MONOBLOCK

UNA PIEZA, SIN PEGADO
ONE PIECE, WITHOUT GLUED



EN 16165
CLASE 3



EN ISO 10545-12
✓



EN 16165
R11



EN 16165
CLASE C



EN ISO 10545-13
GA / GLA / GHA



LARGA VIDA
LONG LIFE



FÁCIL LIMPIEZA
EASY CLEAN

Samoa

Borde de piscina | Pool edge

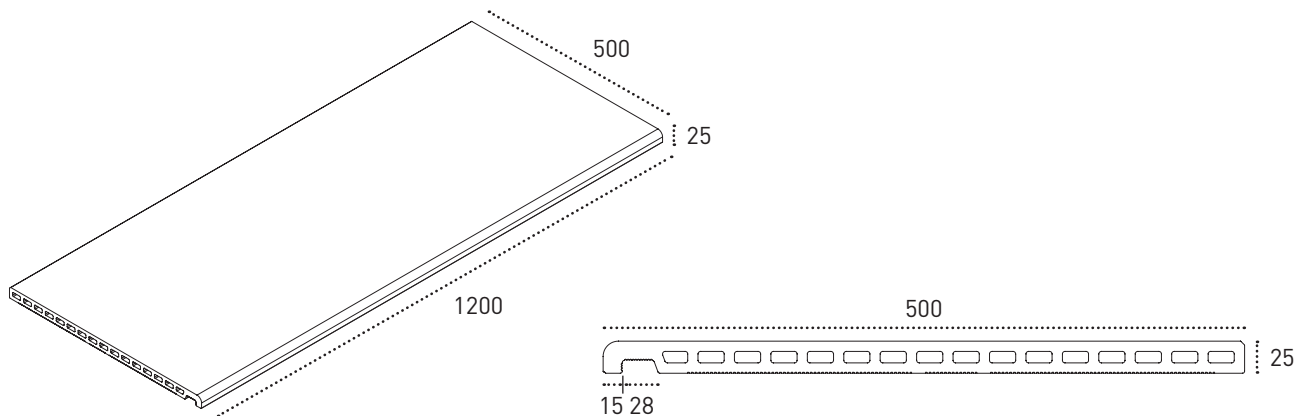

↗ 50x120cm 19.7"x47.6"

C3 **R11** · Ref. BPSA 0000

💧 3 caras | 3 sides

COLORES DISPONIBLES | AVAILABLE COLOURS



Crosscut Puro



Crosscut Petra



Crosscut Cloud



Salem Clar



Lao Bone



Lao Sand

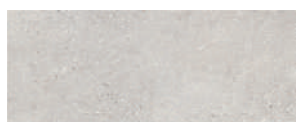

Lao Ash



Stromboli Light



Savoy Moon



Savoy Desert

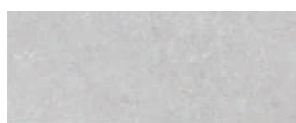

Savoy Land



Stromboli Cream

SOLUCIÓN CURVA | CURVED SOLUTION



BORDE CURVO SAMOA
SAMOA CURVED EDGE

1. BPSA RI00
2. BPSA RE00

SOLUCIÓN ESQUINA | CORNER SOLUTION

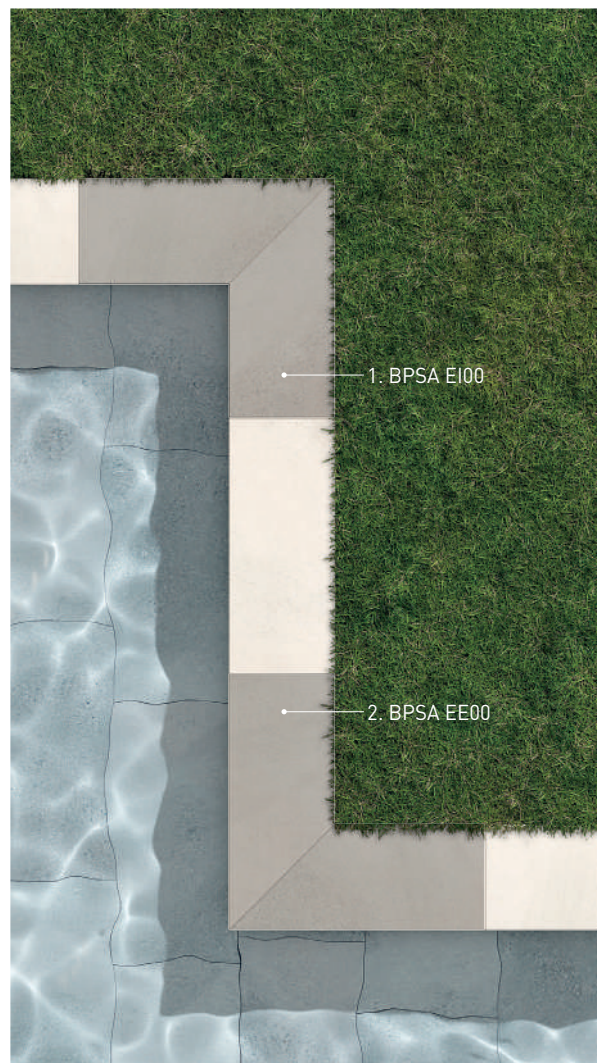

PACK ESQUINA BORDE SAMOA (2pcs)
SAMOA EDGE CORNER PACK (2pcs)

1. BPSA EI00 50x120cm 19.7"x47.6"
2. BPSA EE00 50x120cm 19.7"x47.6"

INFORMACIÓN TÉCNICA | TECHNICAL INFORMATION

MONOBLOCK

UNA PIEZA, SIN PEGADO
ONE PIECE, WITHOUT GLUED



EN 16165
CLASE 3



EN ISO 10545-12
✓



EN 16165
R11



EN 16165
CLASE C



EN ISO 10545-13
GA / GLA / GHA



LARGA VIDA
LONG LIFE



FÁCIL LIMPIEZA
EASY CLEAN

Maui

Borde de piscina | Pool edge

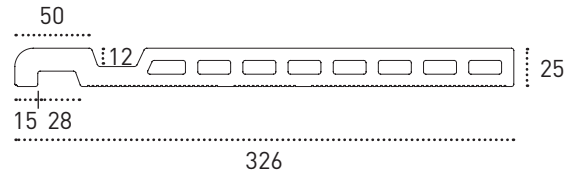
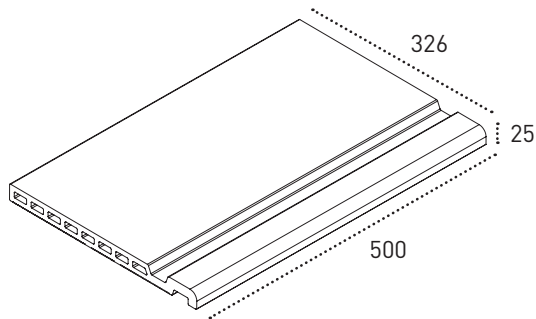

↗ ↘ 32.6x50cm 12.8"x19.7"

C3 R11 • Ref. BPMA 0000

5% 

🔥 3 caras | 3 sides

COLORES DISPONIBLES | AVAILABLE COLOURS



Crosscut Puro



Savoy Moon



Lao Bone



Salem Clar



Crosscut Petra



Savoy Desert



Lao Sand



Veincut Arena



Crosscut Cloud

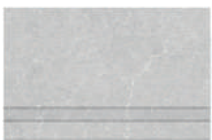

Savoy Land



Lao Ash



Veincut Sahara



Stromboli Light



Stromboli Cream



Stromboli Silver



Veincut Basalt

SOLUCIÓN CURVA | CURVED SOLUTION

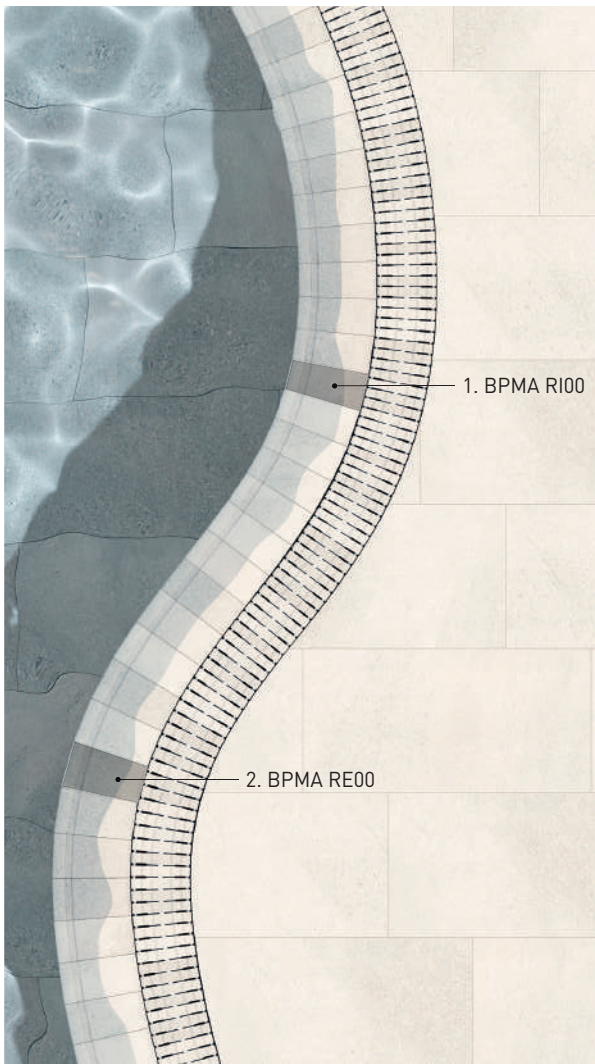

BORDE CURVO MAUI MAUI CURVED EDGE

1. BPMA RI00
2. BPMA RE00

Compatible con las rejillas RJ25, RJ25 FLEX, RJ20, RJ20 FLEX y RJ25 INV
Can be used with drain grates RJ25, RJ25 FLEX, RJ20, RJ20 FLEX and RJ25 INV

SOLUCIÓN ESQUINA | CORNER SOLUTION

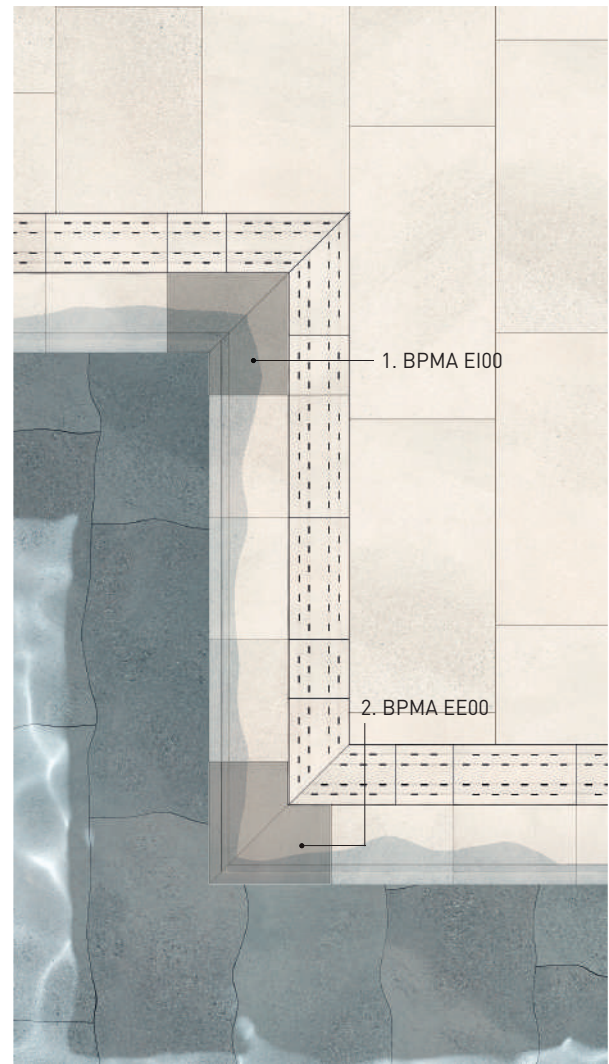

PACK ESQUINA BORDE MAUI (2pcs) MAUI EDGE CORNER PACK (2pcs)

1. BPMA EI00 32.6x50cm 12.8"x19.7"
2. BPMA EE00 32.6x50cm 12.8"x19.7"

Compatible con las rejillas RJ25, RJ25 FLEX, RJ20, RJ20 FLEX y RJ25 INV
Can be used with drain grates RJ25, RJ25 FLEX, RJ20, RJ20 FLEX and RJ25 INV

INFORMACIÓN TÉCNICA | TECHNICAL INFORMATION

MONOBLOCK

UNA PIEZA, SIN PEGADO
ONE PIECE, WITHOUT GLUED



EN 16165
CLASE 3



EN ISO 10545-12
✓



EN 16165
R11



EN 16165
CLASE C



EN ISO 10545-13
GA / GLA / GHA



LARGA VIDA
LONG LIFE



FÁCIL LIMPIEZA
EASY CLEAN

Aruba

Borde de piscina | Pool edge

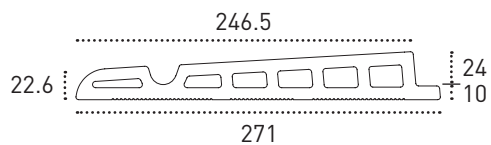
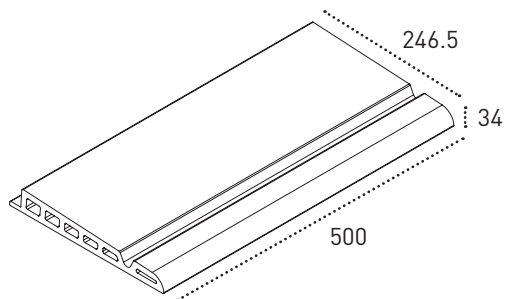

 24,6x50cm 9.7"x19.7"

C3 **R11** • Ref. BPAR 0000

 5% 

COLORES DISPONIBLES | AVAILABLE COLOURS



Stromboli Light



Stromboli Cream



Stromboli Silver



Crosscut Puro



Crosscut Petra



Crosscut Cloud

SOLUCIÓN CURVA | CURVED SOLUTION

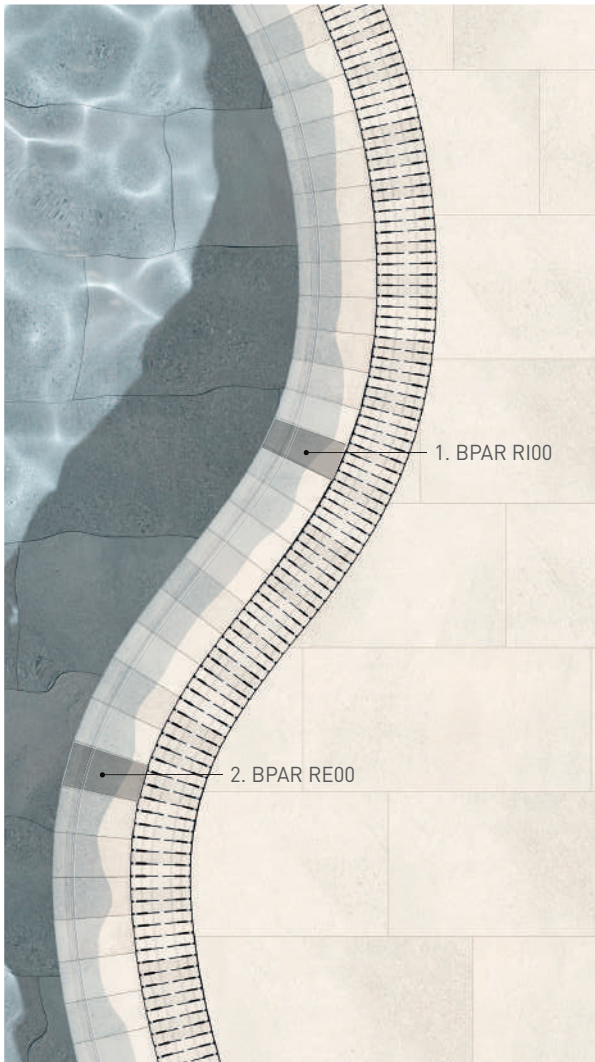

BORDE CURVO ARUBA ARUBA CURVED EDGE

1. BPAR RI00
2. BPAR RE00

Ambos son compatibles con las rejilla Both can be used with drain grates RJ25, RJ25 FLEX, RJ20, RJ20 FLEX and RJ25 INV

SOLUCIÓN ESQUINA | CORNER SOLUTION

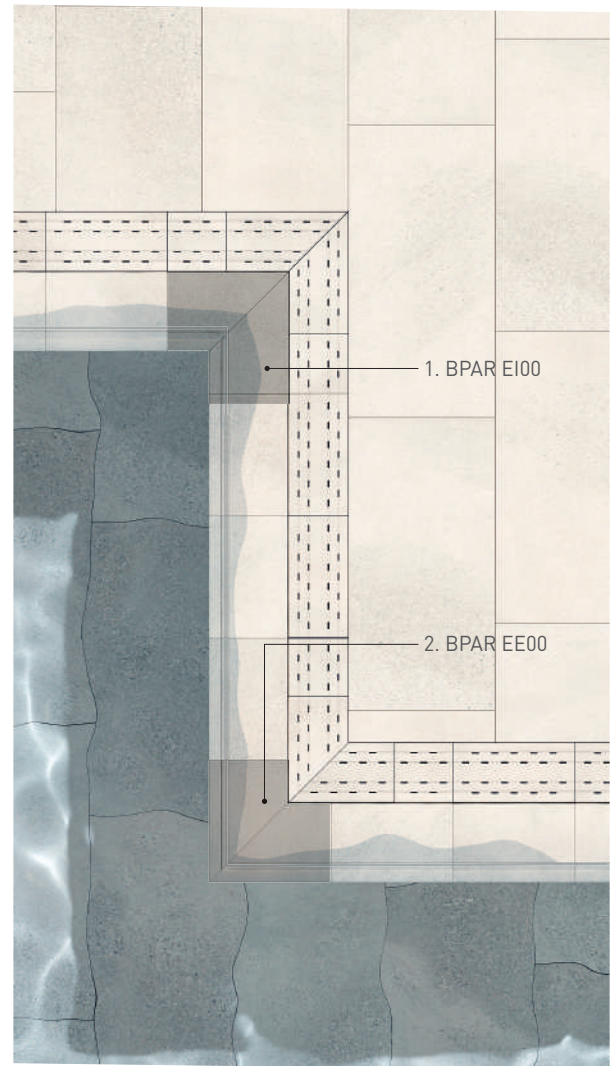

PACK ESQUINA BORDE ARUBA (2pcs) ARUBA EDGE CORNER PACK (2pcs)

1. BPAR EI00 24,6x50cm 9,6"x19.7"
2. BPAR EE00 24,6x50cm 9,6"x19.7"

Ambos son compatibles con las rejillas RJ25, RJ25 FLEX, RJ20, RJ20 FLEX y RJ25 INV Both can be used with drain grates RJ25, RJ25 FLEX, RJ20, RJ20 FLEX and RJ25 INV

INFORMACIÓN TÉCNICA | TECHNICAL INFORMATION

MONOBLOCK

UNA PIEZA, SIN PEGADO
ONE PIECE, WITHOUT GLUED



EN 16165
CLASE 3



EN ISO 10545-12
✓



EN 16165
R11



EN 16165
CLASE C



EN ISO 10545-13
GA / GLA / GHA



LARGA VIDA
LONG LIFE



FÁCIL LIMPIEZA
EASY CLEAN

RJ25

Rejilla de drenaje cerámica | Ceramic drain grate

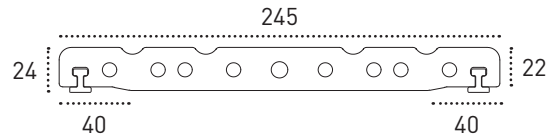
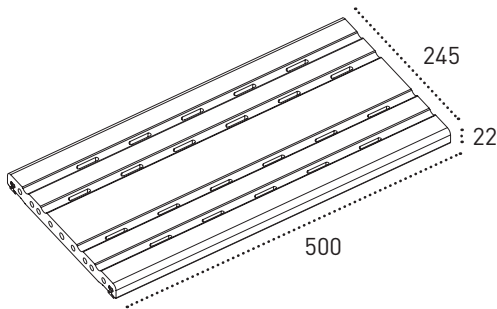

↗ 24,5x50cm 9,6"x19.7"

C3 R11 • 🏠 🌐 • Ref. RJ25 0000

Desagüe | Drain: >13m³/hora

Goma para rejilla 9710 incluida
Grate rubber 9710 included



Esquina rejilla de drenaje
Drain grate corner

↗ 24,5x50cm 9,6"x19.7"

C3 R11 • 🏠 🌐 • Ref. RJ25 E000

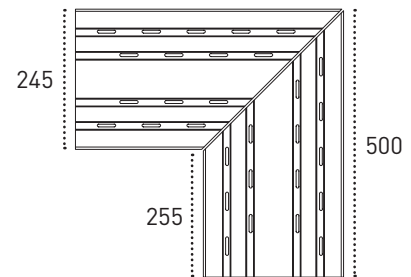

COLORES DISPONIBLES | AVAILABLE COLOURS



Amazonia Miel



Amazonia Canela



Coralina Aguada



Coralina Samaná



Crosscut Puro



Crosscut Petra

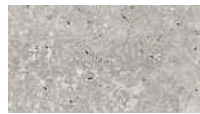

Crosscut Cloud



Veincut Arena



Veincut Sahara



Veincut Basalt



Savoy Moon



Lao Bone



Cupira Hueso



Stromboli Light



Cements Snow



Iconic Stone



Savoy Desert



Lao Sand



Cupira Multi



Stromboli Cream



Cements Warm



Salem Clar



Savoy Land



Lao Ash



Cupira Marengo



Stromboli Silver



Cements Smoke



Salem Dune



RJ25 Flex

Rejilla de drenaje cerámica | Ceramic drain grate

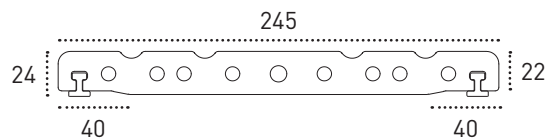
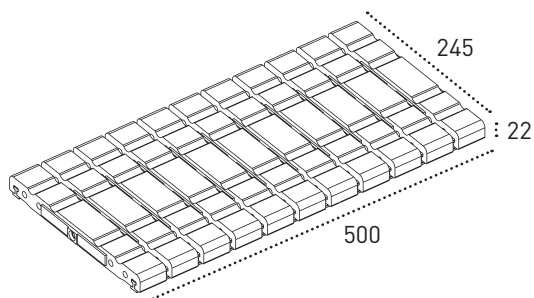

↗ 24,5x50cm 9,6"x19,7"

C3 R11 • 🏠 🌐 • Ref. RJ25 FLEX

Desagüe | Drain: >30m³/hora

Goma para rejilla 9134 incluida
Grate rubber 9134 included



Esquina rejilla de drenaje
Drain grate corner

↗ 25x28cm 9,6"x11"

C3 R11 • 🏠 🌐 • Ref. RJ25 E000 FLEX

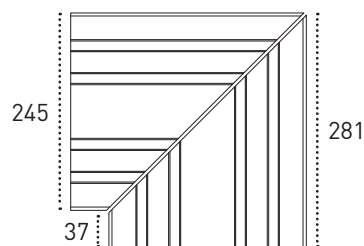

COLORES DISPONIBLES | AVAILABLE COLOURS





RJ20

Rejilla de drenaje cerámica | Ceramic drain grate

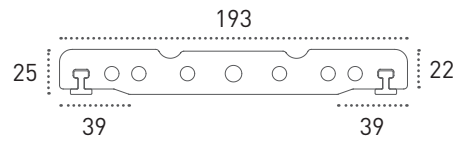
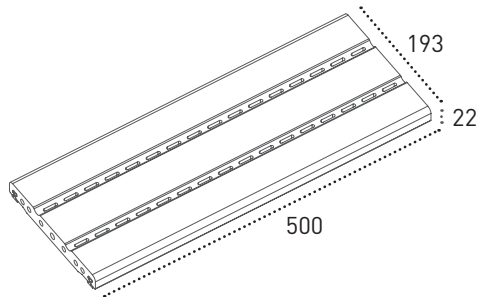

↗ 19.3x50cm 7.6"x19.7"

C3 R11 • 🏠 🌐 • Ref. RJ20 0000

Desagüe | Drain: >11m³/hora

Goma para rejilla 9710 incluida
Grate rubber 9710 included



Esquina rejilla de drenaje
Drain grate corner

↗ 19.3x50cm 7.6"x19.7"

C3 R11 • 🏠 🌐 • Ref. RJ20 E000

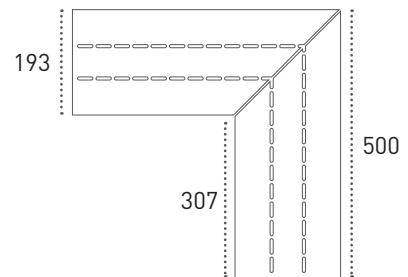

COLORES DISPONIBLES | AVAILABLE COLOURS



Crosscut Puro



Crosscut Petra



Crosscut Cloud



Stromboli Light



Stromboli Cream



Stromboli Silver



Salem Clar



RJ20 Flex

Rejilla de drenaje cerámica | Ceramic drain grate

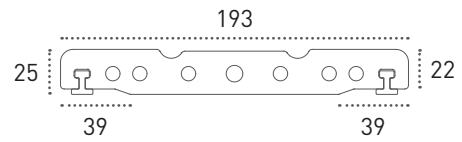
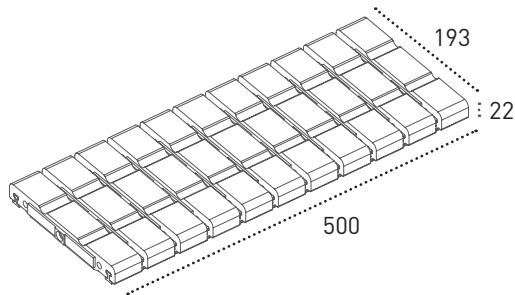

↗ 19.3x50cm 7.6"x19.7"

C3 R11 • 🏠 🌐 • Ref. RJ20 FLEX

Desagüe | Drain: >30m³/hora

Goma para rejilla 9710 incluida
Grate rubber 9710 included



Esquina rejilla de drenaje
Drain grate corner

↗ 20x23cm 7.6"x9"

C3 R11 • 🏠 🌐 • Ref. RJ20 E000 FLEX

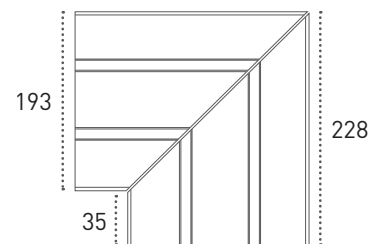

COLORES DISPONIBLES | AVAILABLE COLOURS



Crosscut Puro



Crosscut Petra



Crosscut Cloud



Stromboli Light



Stromboli Cream

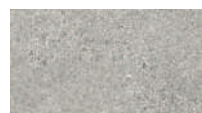

Stromboli Silver



Salem Clar

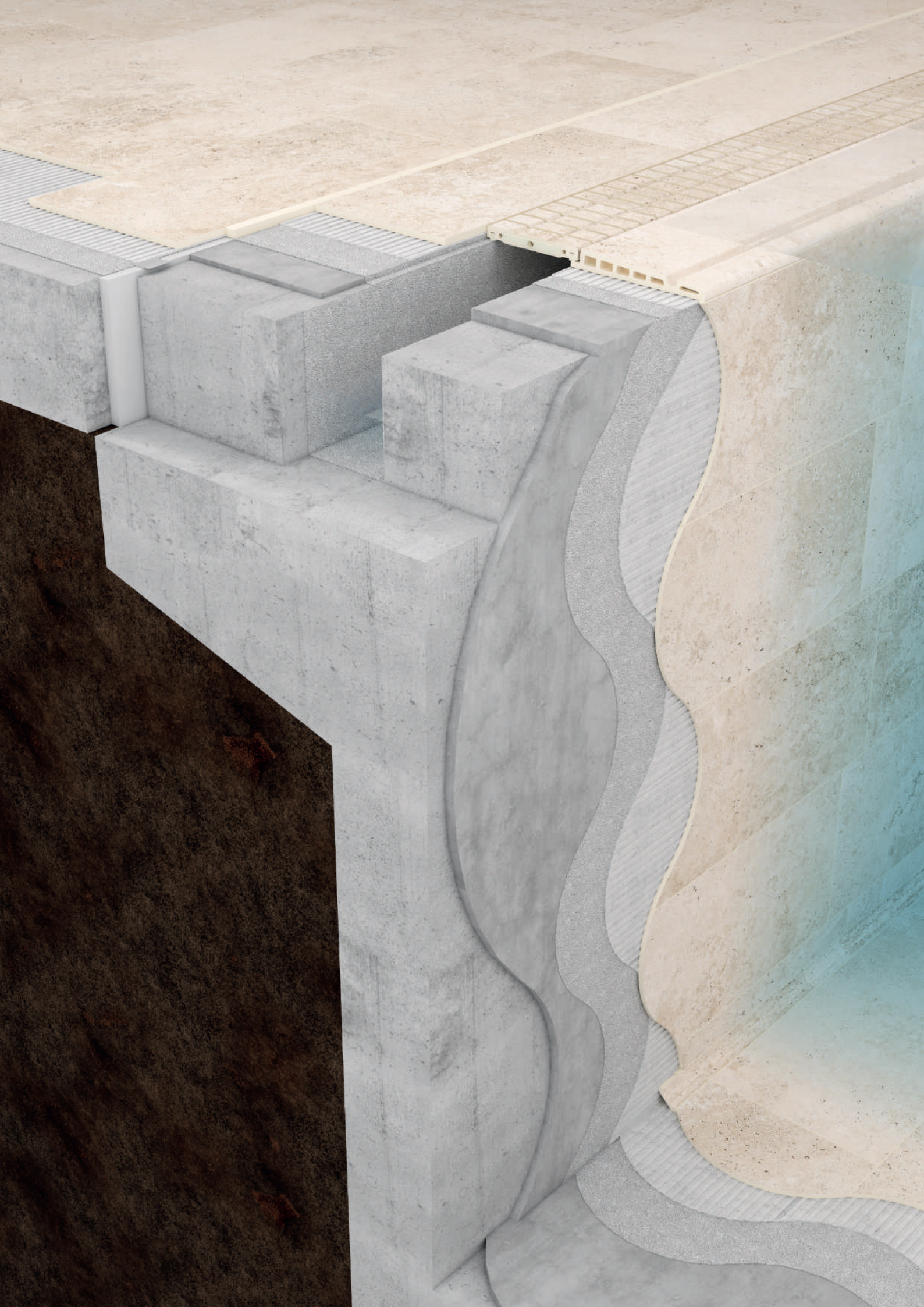

RJ25 Invisible

Rejilla de drenaje cerámica | Ceramic drain grate

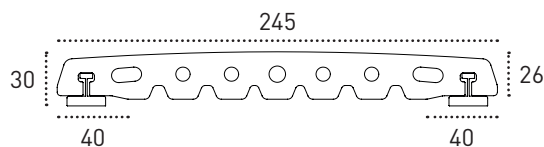
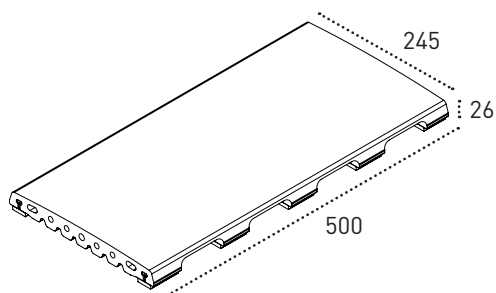

↗ 24,5x50cm 9,6"x19,7"

C3 R11 • 🏠 🌐 • Ref. RJ25 0000 INV

💧 3 caras | 3 sides

Desagüe | Drain: >8m³/hora

Goma para rejilla 12719 incluida
Grate rubber 12719 included



Esquina rejilla de drenaje
Drain grate corner

↗ 24,5x50cm 9,6"x19,7"

C3 R11 • 🏠 🌐 • Ref. RJ25 E000 INV

💧 3 caras | 3 sides

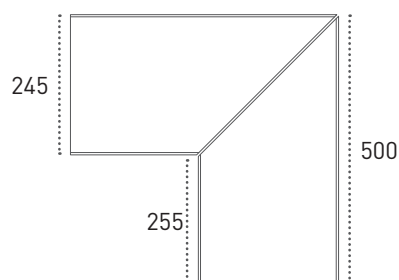

COLORES DISPONIBLES | AVAILABLE COLOURS



Savoy Moon



Stromboli Light



Crosscut Puro



Veincut Arena



Salem Clar



Savoy Desert



Stromboli Cream



Crosscut Petra



Veincut Sahara



Coralina Aguada



Savoy Land



Stromboli Silver



Crosscut Cloud



Veincut Basalt



Coralina Samaná



Piezas de terminación

Trims

1. Media caña exterior | Outer trims

4.5x50cm 1.8"x19.7"

Ref. MDCA E000

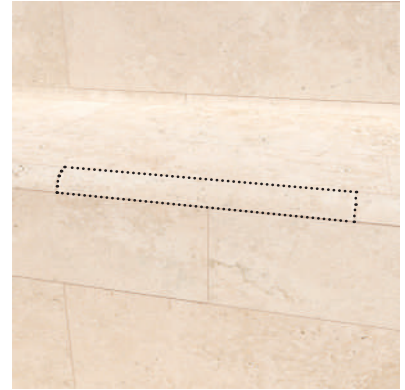

3. Escocia cantonera exterior | Scoth outer corner

4.5x4.5cm 1.8"x1.8"

Ref. MDCA EE00



5. Esquina cantonera exterior | Outer angle corner

6.5x6.5cm 2.6"x2.6"

Ref. MDCA AE00

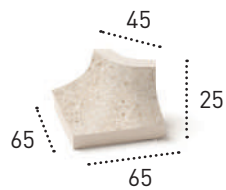

7. Cantonera transición exterior | External transition corner

4.5x25cm 1.8"x9.8"

Ref. MDCA CE00

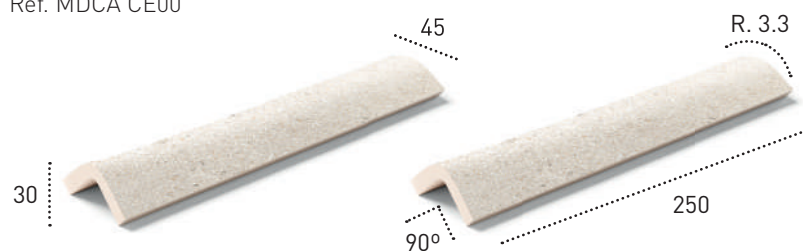

2. Media caña interior | Inner trims

5.5x50cm 2.2"x19.7"

Ref. MDCA I000

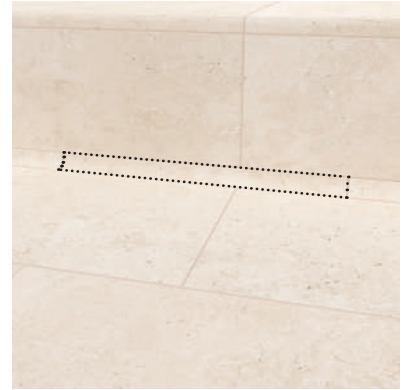

4. Escocia cantonera interior | Scoth inner corner

5.5x5.5cm 2.2"x2.2"

Ref. MDCA EI00

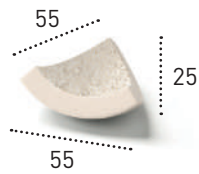

6. Esquina cantonera interior | Inner angle corner

6.5x6.5cm 2.6"x2.6"

Ref. MDCA AI00

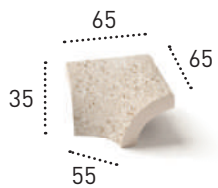

8. Cantonera transición interior | Inner transition corner

5.5x25cm 2.2"x9.8"

Ref. MDCA CI00

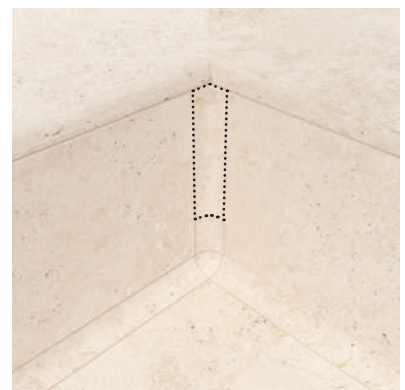
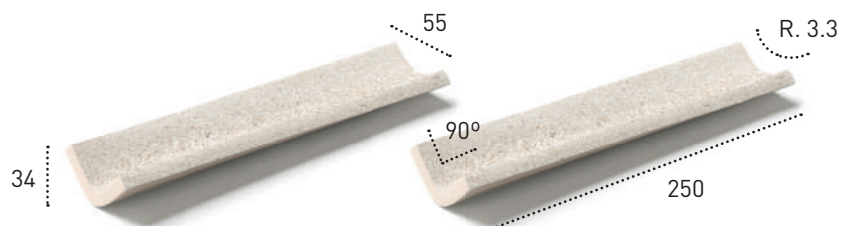



8

4

2

2

6

1

7

5

3

3

1

4

5

COLORES DISPONIBLES | AVAILABLE COLOURS

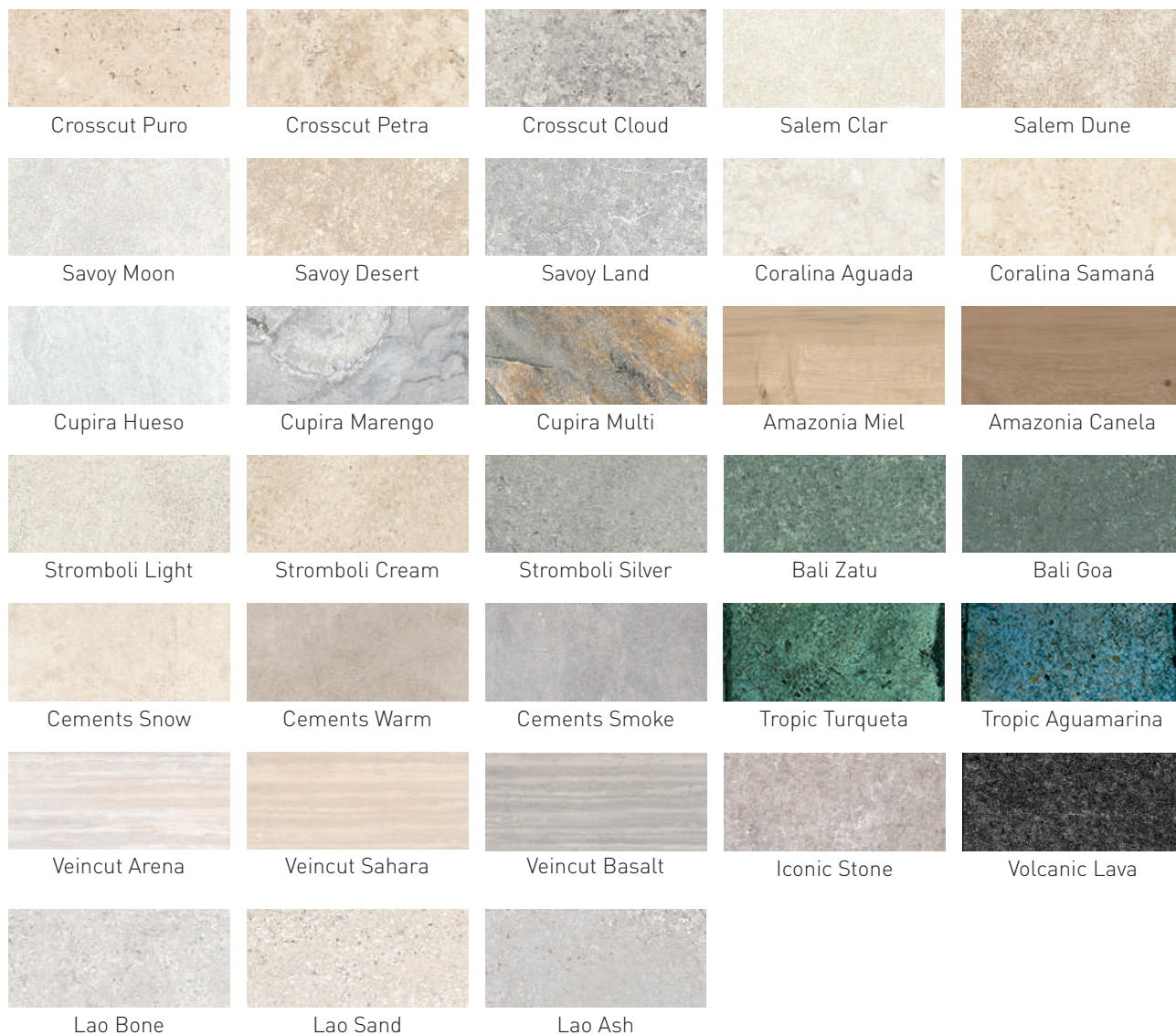

Escanea este QR y visualiza nuestro video de colocación de medias cañas.
Scan this QR and watch our trims installation video.

Recomendaciones de colocación

Placement recommendations

Colocación del pavimento

Laying of flooring

AVISO IMPORTANTE ANTES DE LA PUESTA EN OBRA:

IMPORTANT BEFORE STARTING INSTALLATION, PLEASE NOTE THE FOLLOWING:

- **Verificar que la calidad de la figura impresa en el embalaje se corresponde con la del material solicitado.** Verify that the received material is what the customer ordered.
- **Verificar la ausencia de defectos visibles (baldosas de 1ª calidad).** Ensure that there are no important physical defects (in 1st quality material).
- **Se recomienda, al colocar, mezclar piezas de varias cajas.** It is recommended to mix pieces from several boxes when setting.
- **No se admitirán reclamaciones de problemas derivados del incumplimiento de estas premisas cuando el material ya esté colocado.** Claims will not be accepted when the above conditions have not been fulfilled and the material has been installed.

PARA CUALQUIER RECLAMACIÓN ES NECESARIA LA REFERENCIA DE LA CAJA

THE BOX REFERENCE WILL BE NECESSARY FOR ANY CLAIM

PREPARACIÓN DE LOS MATERIALES

PREPARATION OF MATERIALS

- **Cemento de agarre.** Grip cement.
- **Nivel manual y elementos de medición necesarios.** Spirit level and measuring elements.
- **Cuñas de nivelación.** Levelling wedges.
- **Crucetas.** Auto-levelling spacers.
- **Pasta de rejunte.** Grouting material.
- **Paleta.** Trowel.
- **Llana dentada.** Serrated trowel.
- **Productos de limpieza.** Cleaning products.

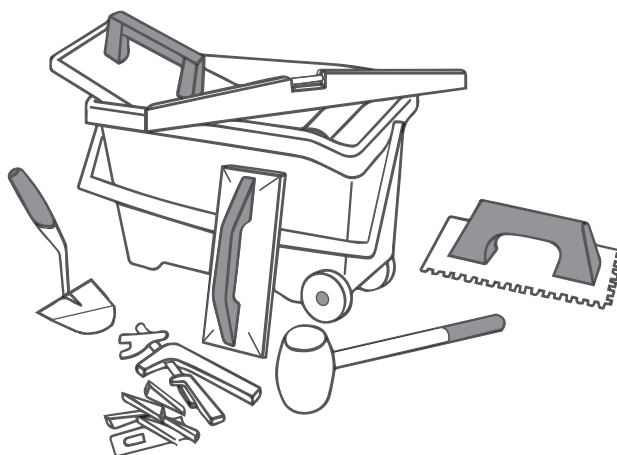

COMPROBAR LA CORRECTA NIVELACIÓN DEL SOPORTE CHECK THE CORRECT LEVELLING OF THE SUPPORT

En terrazas y espacios exteriores es muy importante evacuar el agua correctamente para evitar que ésta quede estancada en la superficie.

On terraces and outdoor spaces it is very important to drain water correctly to prevent it from stagnating on the surface.

Cerámica Mayor recomienda lo siguiente:

Cerámica Mayor recommends the following:

- **Imprescindible dar una pendiente mínima que esté comprendida entre el 1-3%.**
It is essential to provide a minimum slop of between 1-3%.
- **Se deberán colocar los suficientes canales sumideros para que no existan problemas de evacuación de aguas pluviales.** Sufficient drainage channels should be installed to avoid rainwater drainage problems.
- **El terreno tendrá que estar correctamente impermeabilizado y drenado para evitar el ascenso del agua por capilaridad.** The ground must be properly waterproofed and drained to prevent water rising by capillary action.
- **Se deberá de utilizar mortero de nivelación, también conocido como autonivelante con el fin de obtener un soporte sólido preparado para recibir las piezas de gres porcelánico.** Levelling mortar or also known as self-levelling mortar must be used to achieve a solid substrate ready to receive the stoneware tiles.

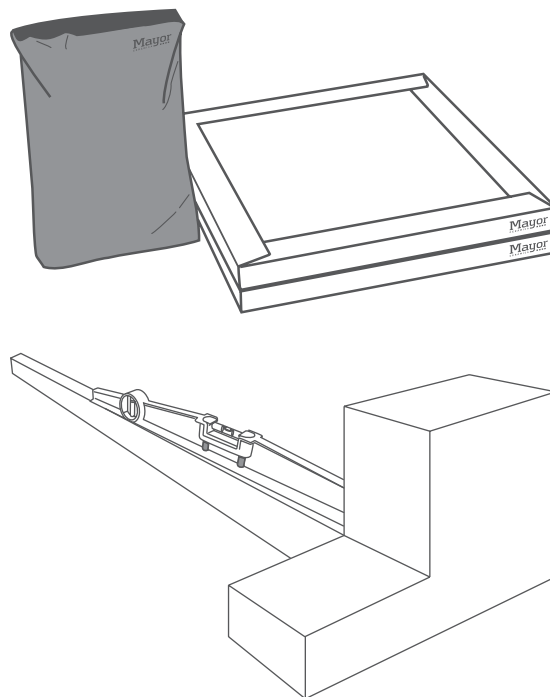

LIMPIEZA DE LA SUPERFICIE SURFACE CLEANLINESS

Se deberá de comprobar que la superficie esté exenta de restos de otros materiales tales como residuos de cemento, grasas, polvo, etc.

The surface must be checked to ensure that it is free of other materials such as cement residues, grease, dust, etc.



REPLANTEO DE LA SUPERFICIE LAYING OUT THE SURFACE

Con el fin de aprovechar al máximo el material cerámico se deberá de establecer una línea principal a partir de la cual se iniciará la colocación.

In order to avoid the wastage of material, a main line should be established from which the tile installation will begin.

Colocación del pavimento

Laying of flooring

En el replanteo se tendrán que tener en cuenta:

In the layout, the following must be taken into account:

- **Juntas perimetrales:** Tendrá que ser > 5,00mm. Perimeter joints: These should be > 5.00mm.
- **Juntas estructurales:** Deberán de coincidir con las juntas estructurales del edificio y serán como mínimo de 10mm y tendrán que ser de un material flexible. Structural joints: These shall coincide with the structural joints of the building and shall be at least 10mm and be made of a flexible material.
- **Junta de partición:** En áreas entre 20-30m² o 6-8ml se requerirá de una junta de partición de > 5,00mm. Partition joint: In areas between 20-30m² or 6-8ml a partition joint of > 5.00mm will be required.
- **Juntas de colocación:** Para la colocación de Material Rectificado se requiere una junta de colocación >2,50 mm. Para la colocación de Material No Rectificado se requiere una junta de colocación >4,00mm, y además, se colocarán de forma trabada o en espiga (no se colocarán a más de 1/4 de su dimensión). Tile joints: For the installation of Rectified Material, a tile joint >2.50mm is required. For the installation of Not Rectified Material is necessary a tile joint >4.00mm, and in addition, they shall be installed in a random laying or herringbone manner (they shall not be installed at more than 1/4 of their dimension).

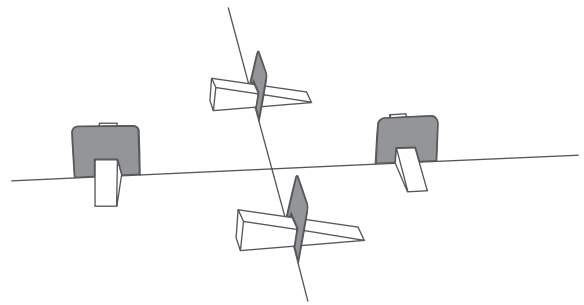
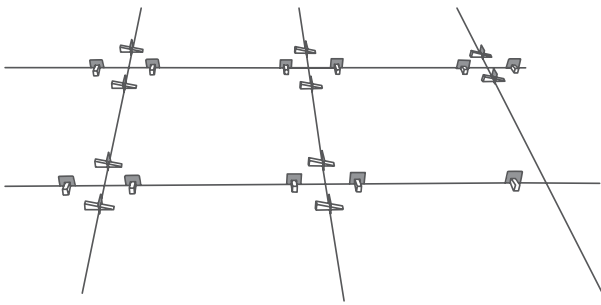

ELECCIÓN Y COLOCACIÓN DEL MATERIAL DE AGARRE CHOICE AND INSTALLATION OF THE BONDING MATERIAL

El material adhesivo a utilizar será cemento cola flexible C-2 TE S2 apropiado para la instalación de pavimento de gres porcelánico.

The adhesive material to be used shall be C-2 TE S2 flexible cementitious adhesive suitable for the installation of porcelain stoneware flooring.

- **C: Adhesivo cementoso.** Cementitious adhesive.
- **2: Adhesivo mejorado.** Improved adhesive.
- **T: Adhesivo con deslizamiento reducido.** Reduced slip adhesive.
- **E: Adhesivo con tiempo abierto ampliado.** Adhesive with extended open time.
- **S2: Adhesivo altamente deformable.** Highly deformable adhesive.



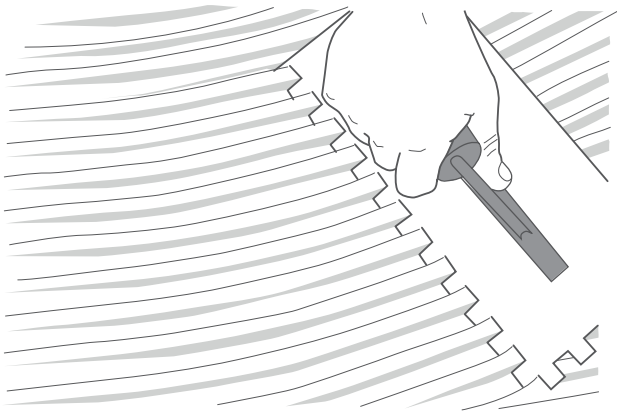

Una vez preparada la mezcla siguiendo las instrucciones del fabricante del producto, extenderemos con la ayuda de una llana dentada el cemento de agarre sobre la superficie previamente compacta y nivelada.

Se deberá extender también cemento de agarre en la parte posterior de la pieza con una llana dentada, generando de esta forma un doble encolado.

Once the mixture has been prepared according to the product manufacturer's instructions, spread the bonding cement on the previously compacted and levelled surface with the help of a notched trowel.

The bonding cement should also be spread on the back of the workpiece with a notched trowel, thus creating a double bond.

INSTALACIÓN DE LA PIEZA CERÁMICA INSTALLATION OF THE CERAMIC TILE

Con la ayuda de una maza de goma flexible se fijará la baldosa cerámica eliminando posibles burbujas de aire producidas por el material de agarre.

With the help of a flexible rubber mallet, the ceramic tile will be fixed, eliminating possible air bubbles produced by the bonding material.

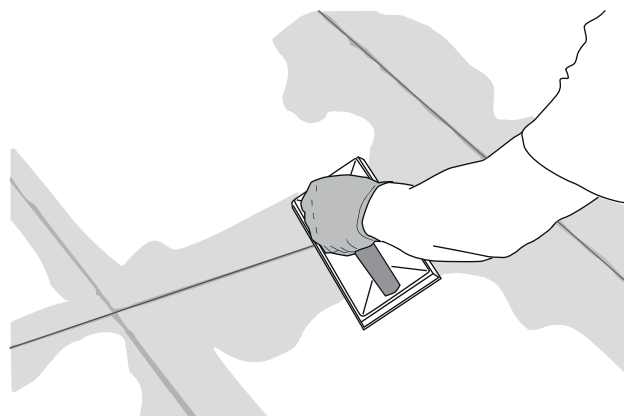
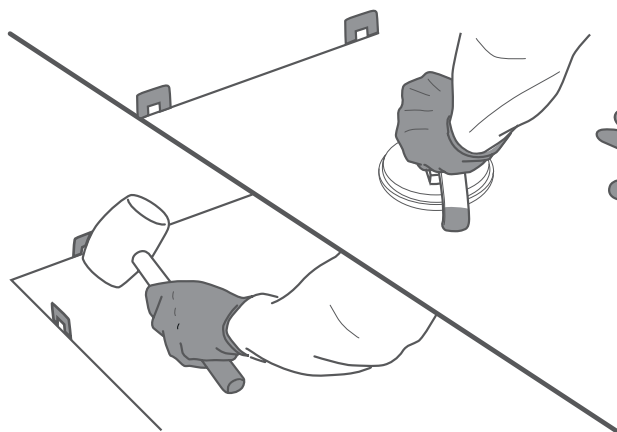

ELECCIÓN Y COLOCACIÓN DE MATERIAL DE REJUNTE CHOICE AND INSTALLATION OF GROUT

El material de rejunte a utilizar en las juntas perimetrales, juntas de colocación y juntas de partición sera rejuntado cementoso mejorado tipo CG2. Una vez preparada la mezcla, siguiendo las instrucciones del fabricante del producto, extenderemos el material de rejuntado entre la separación de las piezas y se fijará con la ayuda de una llana de rejuntado.

The grout material to be used in the perimeter joints, tile joints and partition joints shall be CG2 type improved cementitious grout. Once the mixture has been prepared, following the product manufacturer's instructions, spread the grout between the separation of the pieces and fix it with the help of a grout trowel.

Colocación del pavimento

Laying of flooring

30x60 | 60x120 | 37.5x75

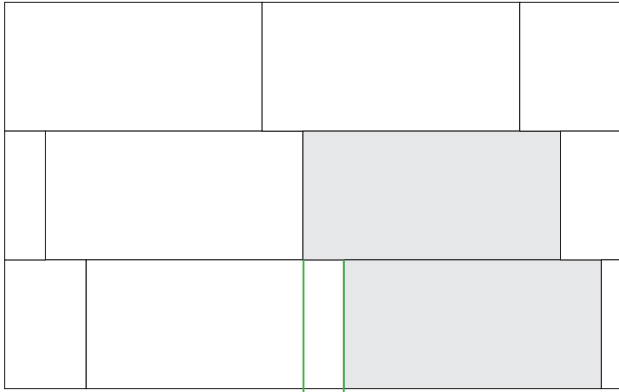

Máximo 20cm
Maximum 20cm

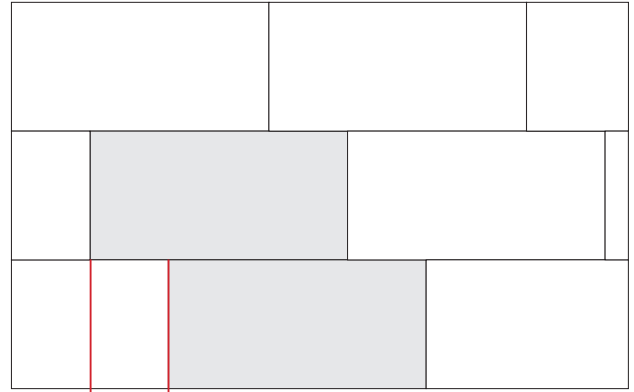

Más de 20cm
More than 20cm



20x120 | 30x120

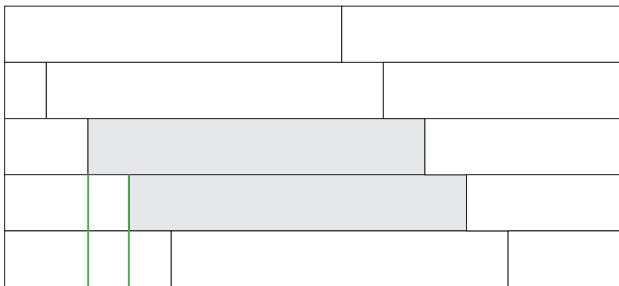

Máximo 20cm
Maximum 20cm

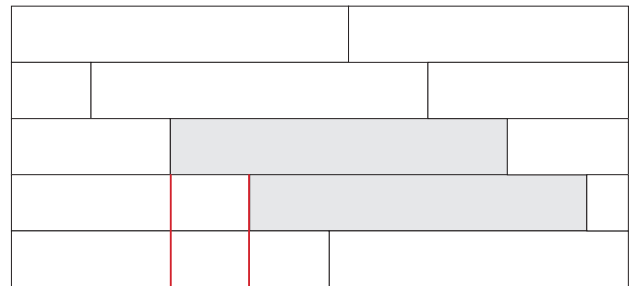

Más de 20cm
More than 20cm



120x120 | 90x90 | 75x75 | 60x60 | 14.7x14.7

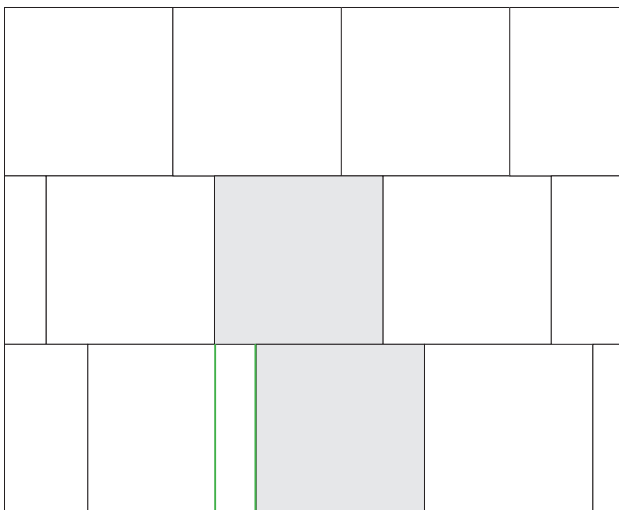

Máximo 20cm
Maximum 20cm

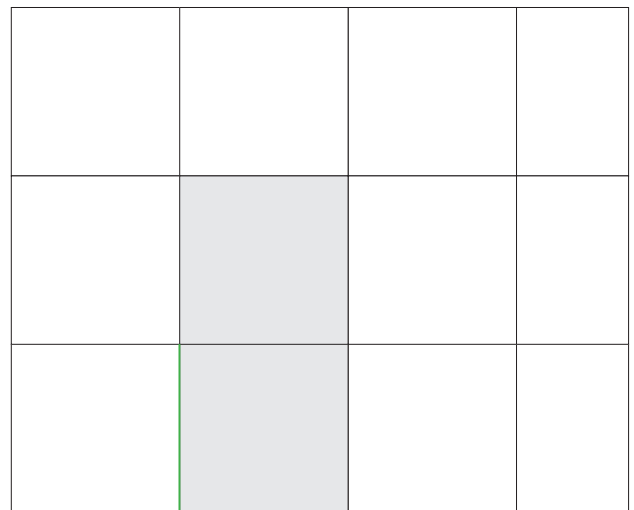

Máximo 20cm
Maximum 20cm



Escanea este QR y visualiza nuestro manual de limpieza tras la colocación.
Scan this QR and view our cleaning manual after installation.

Colocación de peldaños

Placement of steps

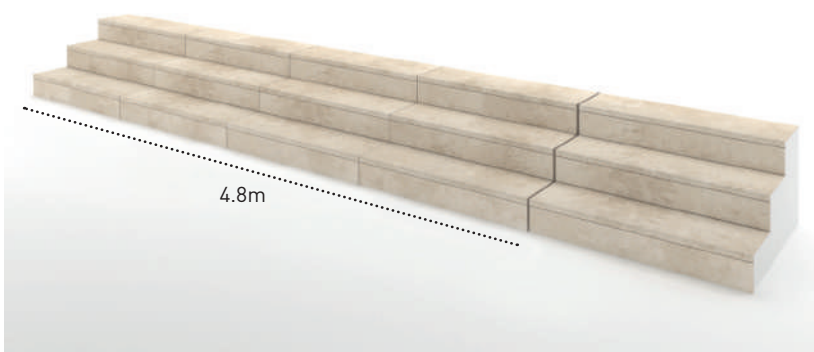

PLANIFICACIÓN

Nos aseguraremos de que las medidas de nuestro material encajan en la escalera. Debemos tener en cuenta todo tipo de juntas: estructurales, perimetrales, de dilatación, y de colocación.

SETTING-OUT ON SITE

We recommend to ensure that all the tiles fit properly at the stairs. At this point, it is important to consider all the necessary joints: expansion joints, perimeter joints, tile-to-tile joints and structural joints.

SUPERFICIE Y ENCOLADO

La superficie debe estar bien conformada y seca. Eliminamos cualquier resto de suciedad. El adhesivo se extiende sobre el escalón de obra y sobre el peldaño. A continuación, colocamos el peldaño totalmente apoyado sobre la escalera.

SURFACE AND ADHESIVE METHOD

The support surface should be well-formed, clean and dry. The adhesive is spread both, on the back side of the step tile and on the support. Then, the step tile should be positioned completely resting on the support.

IMPORTANTE

Para una correcta instalación de los peldaños es necesario utilizar junta elástica impermeable y cemento cola flexible. Comprobamos las piezas y ajustamos los niveles.

IMPORTANT

We recommend to use appropriate bonding materials: the adhesive should be high-adherence and flexible and the grouts past should be waterproof and elastic. The level should be checked and adjusted.

JUNTAS

Junta entre peldaños entre 6 y 10mm. La junta de dilatación debe hacerse cada 4 metros.

JOINTS

We recommend to use a tile-to-tile joint between 6 and 10mm. We recommend to install an expansion joint each 4m.



EL RODAPIÉ COMO SOLUCIÓN PARA ZANQUINES
SKIRTING BOARD APPLICATIONS

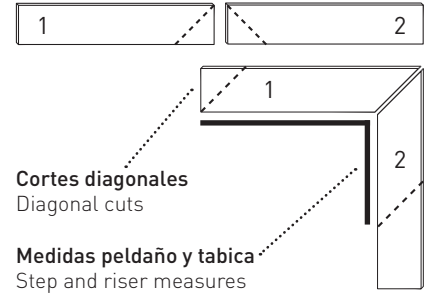

Tipos de peldaños

Types of steps

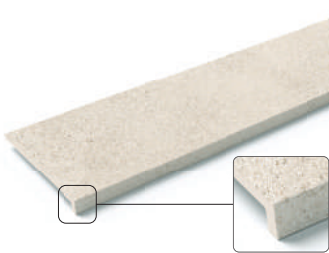

Peldaño recto
Recto step

32.6x120cm 12.8"x47.2"

3.4cm 1.3"

1.1cm 0.43"

C3 R11 · C1 R9

MONOBLOCK

Una pieza, sin pegado
One piece, without glued



Peldaño recto tapa
Recto step corner

32.6x120cm 12.8"x47.2"

3.4cm 1.3"

1.1cm 0.43"

C3 R11 · C1 R9



Peldaño completo
Full step

32.6x120cm 12.8"x47.2"

2.4cm 0.94"

3 caras | 3 sides

C3 R11

MONOBLOCK

Una pieza, sin pegado
One piece, without glued



Escanea este QR y visualiza nuestro video de colocación de peldaños.
Scan this QR and watch our step installation video.

Colocación piezas especiales para piscinas

Installation of special pieces for swimming pools

Una vez se haya ejecutado el vaso de la piscina y preparado el soporte para recibir el material cerámico, Cerámica Mayor sugiere seguir los siguientes pasos para conseguir una correcta ejecución en la colocación de las piezas especiales de borde.

Once we have prepared the pool vessel, Cerámica Mayor suggests the following steps to achieve a correct execution in the placement of special pieces for pool edges.

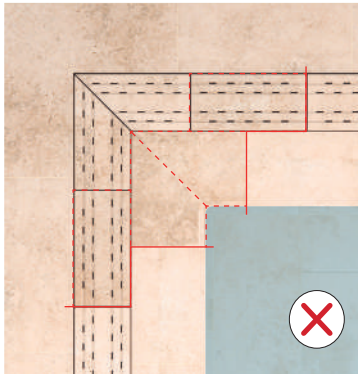

Una colocación incorrecta puede producir roturas en las piezas.

Incorrect alignment or placement of the pieces can cause breakages in pieces.

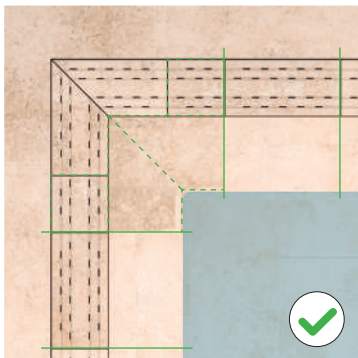

Alineación correcta de las piezas. Estas piezas se deberán de cortar y ajustar en obra.

Correct alignment of pieces. These pieces must be cut and adjusted on-site.

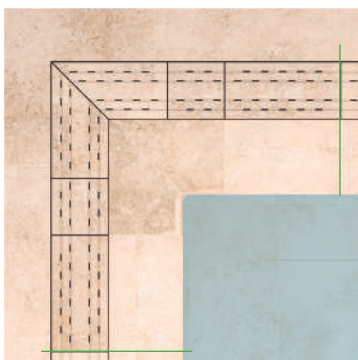

La colocación de las piezas deberá de empezar de los extremos hacia el centro de cada uno de los lados, manteniendo la linealidad de las piezas.

The placement of the pieces must start from the corners to the center of each side, keeping the linearity of the pieces.

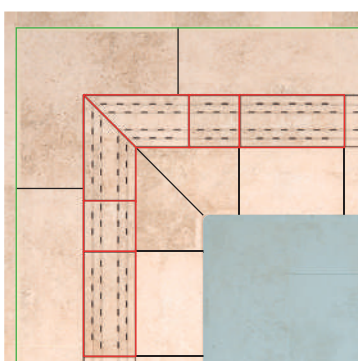

Las juntas de expansión son muy importantes en la colocación de las piezas para evitar posibles roturas.

Cerámica Mayor recomienda:

- Junta abierta mínima 4mm
- Junta cerrada mínima 4mm
- Junta de dilatación

The expansion joints are very important to ensure correct ceramic pieces placement and to avoid possible breakages.

Cerámica Mayor recommends:

- Open joint minimum 4 mm size
- Closed joint minimum 4 mm size
- Expansion joint

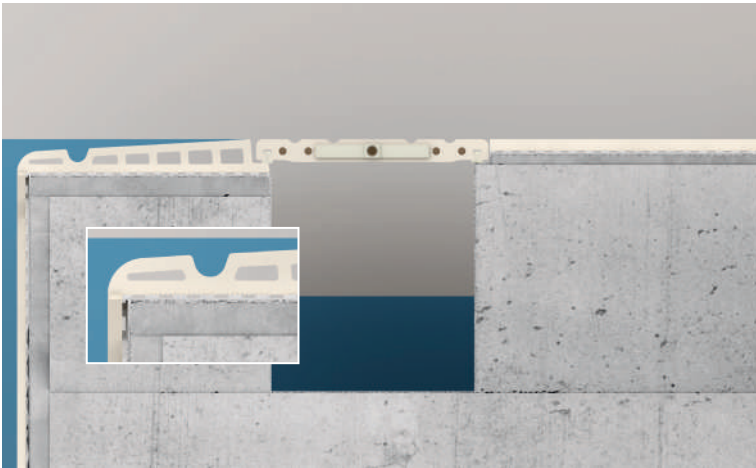

La rejilla deberá apoyar en las pestañas del borde y del soporte, colocando siempre la goma proporcionada por Cerámica Mayor. Nunca se debe de colocar la rejilla sin junta debido a las contracciones y dilataciones que pueden sufrir las piezas. Se debe emplear mortero cola flexible, estanco y antiácido para la colocación del borde y soporte.

The drain grate must be placed over the edge and support flanges, and always with the rubber provided by Cerámica Mayor. The drain grate should never be placed without joints due to the contractions and dilatations that pieces may suffer. Flexible, watertight and anti-acid tail mortar must be used for correct edge and support placement.

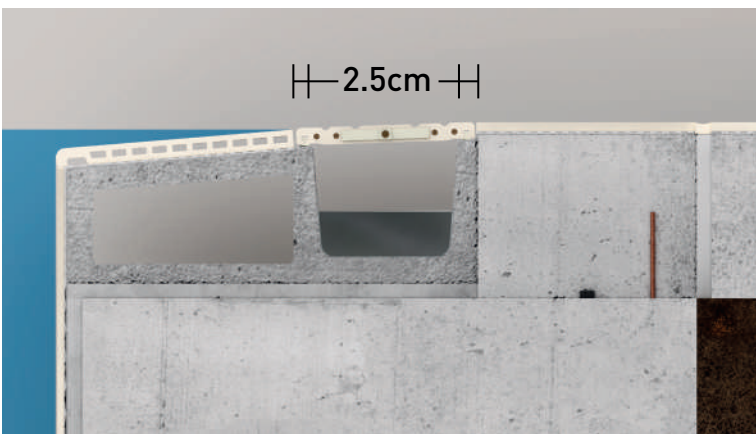

La rejilla apoyará al menos 2,5cm en cada uno de sus extremos. Nunca se debe de colocar la rejilla sin junta debido a las contracciones y dilataciones que pueden sufrir las piezas. Se debe emplear mortero cola flexible, estanco y antiácido para la colocación del borde.

In case the edge has no flange, the drain grate shall be supported by at least 2.5 cm at each end. The drain grate should never be placed without joints due to the contractions and dilatations that pieces may suffer. Flexible, watertight and anti-acid tail mortar must be used for correct edge placement.

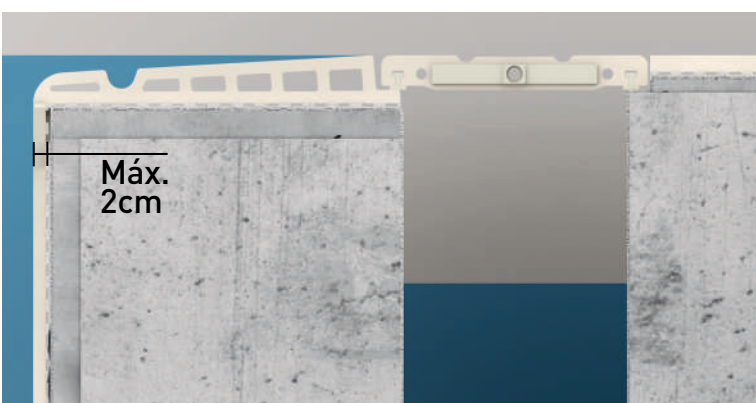

Cerámica Mayor sugiere que la pieza de borde no sobresalga más de 2cm respecto el paramento vertical del vaso de la piscina. Un excesivo vuelo de la pieza podrá provocar una rotura en la misma.

Cerámica Mayor suggests that the edge pieces never protrude more than 2 cm beyond the vertical wall of the pool shell.



Escanea este QR para acceder al apartado de colocación de nuestra web y obtener más información.
For more information, scan this QR to access the placement section of our website.

Instalación sistema Block25 para piscinas

Installation of Block25 system for swimming pools

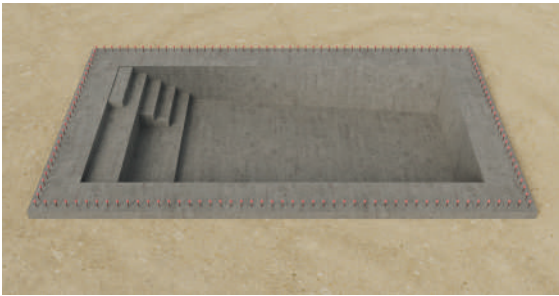

Se realiza el hormigonado del vaso, dejando una zona de recepción para el sistema Block 25 y unas armaduras de espera para el talón posterior.

The concrete is poured into the tank, leaving a reception area for the Block 25 system and waiting reinforcement for the subsequent heel.

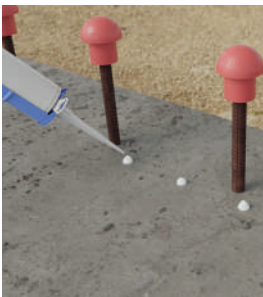

Se colocan puntos de adhesivo de base polimérica con silicona para el pegado de la junta hidro-expansiva. Sobre los puntos de adhesivo se fija un cordón hidro-expansivo para conseguir un correcto sellado.

Dots of polymer-based adhesive with silicone are applied for the bonding of the hydro-expansive joint. A hydro-expansive bead is fixed over the adhesive points to achieve a proper seal.



Para fijar el Sistema Block 25 se empleará un mortero aditivo que garantice una correcta adhesión. Con la ayuda de un láser, comprobaremos que el sistema Block 25 está correctamente nivelado. En primer lugar, colocaremos las piezas especiales de esquina.

To fix the Block 25 System, an additive mortar shall be used to ensure correct adhesion. With the help of a laser, we will check that the Block 25 system is correctly levelled. First, we will place the special corner pieces.



En segundo lugar, se colocarán el resto de los bloques aplicando mortero tanto en la base como en los laterales de cada uno de los bloques para que el sistema Block 25 quede totalmente instalado en todo el perímetro de la piscina.

Secondly, the rest of the blocks will be placed by applying mortar to both the base and the sides of each of the blocks so that the Block 25 system is completely installed around the perimeter of the pool.



Se quitan las setas de seguridad de PVC y se coloca un encofrado de madera para realizar el talón posterior.

The PVC safety caps are removed and a wooden formwork is put in place to make the rear heel.

Escanea este QR y visualiza el vídeo de instalación del sistema Block25.

Scan this QR and view our Block25 system installation video.



Se realiza el recrecido de mortero adhesivo asegurándonos que el sistema Block 25 queda perfectamente alineado con el paramento vertical de la piscina.

The adhesive mortar screed is applied, ensuring that the Block 25 system is perfectly aligned with the vertical face of the swimming pool.



Junta de dilatación | Expansion Joint

Se realiza la losa de hormigón de la terraza adyacente a la piscina y se impermeabiliza el vaso y el canal con dos capas de mortero flexible y 100% estanco. Posteriormente, se ejecuta la junta de dilatación alrededor de la piscina para que los movimientos de la terraza no la afecten.

The concrete slab of the terrace adjacent to the swimming pool is made and the basin and the channel are waterproofed with two layers of flexible, 100% watertight mortar. Next, the expansion joint is made around the swimming pool so that the movements of the terrace do not affect it.



Con la ayuda de una llana dentada, aplicamos cemento cola flexible apta para gres porcelánico. Posteriormente, colocamos los bordes de piscina Cerámica Mayor que encajan a la perfección con el sistema Block 25. La pieza de borde se coloca a lo largo de todo el perímetro de la piscina.

With the help of a notched trowel, we apply flexible cement glue suitable for porcelain stoneware, and then we place the pool edges by Cerámica Mayor that fit perfectly with the Block 25 system. The border piece is placed along the entire perimeter of the pool.



Se colocan las rejillas de drenaje por todo el perímetro de la piscina empezando por las esquinas. Se apoyarán sobre la canal gracias al sistema de gomas patentado por la marca.

The drainage gratings are placed around the entire perimeter of the pool starting from the corners. They will rest on the channel thanks to the rubber system patented by the brand.



Se colocan las rejillas de drenaje por todo el perímetro de la piscina empezando por las esquinas. Se apoyarán sobre la canal gracias al sistema de gomas patentado por la marca. Finalmente, se aplica un rejuntado cementoso, y finalizada la piscina se pavimenta la terraza.

The drainage gratings are placed around the entire perimeter of the pool starting from the corners. They will rest on the channel thanks to the rubber system patented by the brand. To finish, a cementitious grout is applied, and once the pool is finished, the terrace is paved.

Dimensiones de las piezas

Pieces dimensions



↖ ↗ 14.7x14.7cm 5.7"x5.7"

↕ 0.8cm 0.3"

C3 R11 · 3-C



↖ ↗ 14.7x14.7cm 5.7"x5.7"

↕ 0.83cm 0.32"

C1 R9 · 1-A

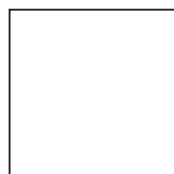

↖ ↗ 60x60cm 23.6"x23.6"

↕ 0.9cm 0.35"

C3 R11 · C1 R9 · R

3-C 1-A



↖ ↗ 30x60cm 11.8"x23.6"

↕ 0.9cm 0.35"

C3 R11 · R

3-C

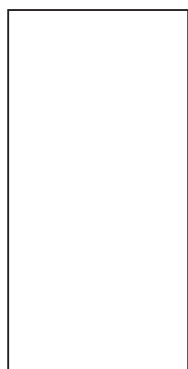

↖ ↗ 60x120cm 23.6"x47.2"

↕ 1.02cm 0.4"

C3 R11 · C1 R9 · R

3-C 1-A

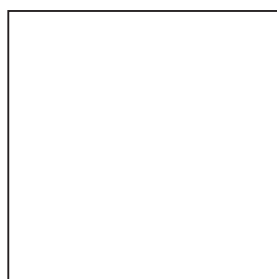

↖ ↗ 90x90cm 35.4"x35.4"

↕ 0.9cm 0.35"

C3 R11 · C1 R9 · R

3-C 1-A

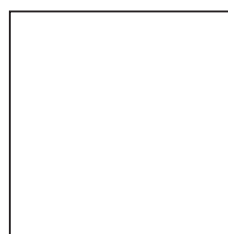

↖ ↗ 75x75cm 29.5"x29.5"

↕ 0.9cm 0.35"

C3 R11 · C1 R9 · R

3-C 1-A

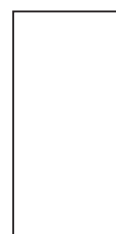

↖ ↗ 37.5x75cm 14.7"x29.5"

↕ 0.9cm 0.35"

C3 R11 · R

3-C

↖ ↗ 60x120cm 23.6"x47.2"

↕ 2cm 0.78"

C3 R11 · R · 3-C

↖ ↗ 90x90cm 35.4"x35.4"

↕ 2cm 0.78"

C3 R11 · R · 3-C



↖ ↗ 20x120cm 7.8"x47.2"

↕ 0.9cm 0.35"

C3 R11 · C1 R9 · R

3-C 1-A

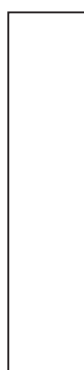

↖ ↗ 30x120cm 11.8"x47.2"

↕ 0.9cm 0.35"

C3 R11 · C1 R9 · R

3-C 1-A

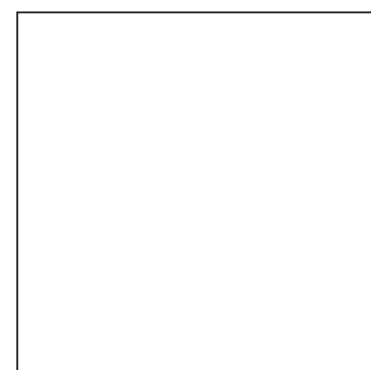

↖ ↗ 120x120cm 47.2"x47.2"















↕ 0.9cm 0.35"

C3 R11 · C1 R9 · R

3-C 1-A

Información técnica del pavimento

Technical information of the pavement

	Resistencia a la abrasión Resistance to surface abrasion	EN ISO 10545-7 PEI IV-V
	Resistencia a la helada Frost resistance	EN ISO 10545-12
	Resistencia al choque térmico Thermal shock resistance	EN ISO 10545-9
	Resistencia a la flexión Bending strenght	EN ISO 10545-4 >23N/mm ²
	Antideslizante OUT Antislip OUT	Deslizamiento EN 16165 Clase 3
	Antideslizante OUT Antislip OUT	EN 16165 R11
	Antideslizante OUT Antislip OUT	EN 16165 Clase C
	Resistencia a las manchas Stain resistance	EN ISO 10545-14 5
	Resistencia química Chemical resistance	EN ISO 10545-13 GA/GLA/GHA
	Resistencia al rayado OUT Scratch resistance OUT	UNE 67101 9
	Absorción de agua Water absortion	EN ISO 10545-3 <0,5%
	Resistencia al fuego Fire resistance	CLASE A1fl Sin necesidad de ensayo (Decisión 96/603/ECC Modificada)
	Resistencia al impacto Impact resistance	EN ISO 10545-5
	Tolerancia dimensional Dimensional tolerance	

Ventajas

Advantages



Resistencia a la flexión
Bending strength



Resistencia a la helada
Frost resistance



Ecológico
Ecological



Resistencia química
Chemical resistance



Ignífugo
Fire resistance



Máxima resistencia al fuego y al calor
Maximum fire and heat resistance



Resistencia al rayado
Scratch resistance



Color duradero
Durable colour



Fácil limpieza y mínimo mantenimiento
Easy to clean and minimum maintenance



Resistencia al choque térmico
Thermal impact resistance



Antiestático
Antistatic



Multiformato
Multi-format



Resistencia a la abrasión
Abrasion resistance



Baja absorción
Low absorption



Piezas especiales
Special pieces



Resistencia al desgaste
Wear resistance



Durabilidad
Durability



Resistencia a los rayos UV
UV resistance



Resistencia a las manchas
Stain resistance



Fácil colocación
Easy to install



Antideslizante para exteriores
Non-slip for outdoor use



Formatos	120x120 47.2"x47.2"	90x90 35.4"x35.4"	75x75 29.5"x29.5"	60x60 23.6"x23.6"	14.7x14.7* 5.8"x5.8"	30x60 11.8"x23.6"	37.5x75 14.7"x29.5"	60x120 23.6"x47.2"	30x120 11.8"x47.2"	20x120 7.8"x47.2"	BPCR 33x50	BPSA 50x120	BPMA 33x50	BPAP* 25x50	REJILLAS DRAIN GRATE	PELD. 32.6x120	MDCA
----------	------------------------	----------------------	----------------------	----------------------	-------------------------	----------------------	------------------------	-----------------------	-----------------------	----------------------	---------------	----------------	---------------	----------------	-------------------------	-------------------	------

Crosscut Puro Petral Cloud							C3	2cm 0.78"							Todas All		
Veincut Arenal Sahara Basalt															RJ25, RJ25 FLEX INV.		
Savoy Moon Desert Land		2cm 0.8"													RJ25, RJ25 FLEX INV.		
Stromboli Light Cream Silver				C3			C3	2cm 0.78" Light				Light, Cream			Todas All	PELD. STEP COMP.	
Cupira Multi Hueso Marengo					Marengo Multi		C3	C3= Hueso, Marengo CI= Hueso							RJ25 RJ25 FLEX		
Salem Dune Clar		2cm 0.8" Clar		Clar				Clar			Clar		Clar		Todas All RJ20 = Clar INV.		
Coralina Azuada Samaná															RJ25 RJ25 FLEX INV.		
La'o Bone Sand Ash															RJ25 RJ25 FLEX		
Eterna Cendra Alba																	
Iconic Stone															RJ25 RJ25 FLEX		
Calacatta Fresh																	
Cements Snow Warm Smoke							C3	Snow							RJ25 RJ25 FLEX		
Cotto Boho																	
Amazonia Miel Canela															RJ25 RJ25 FLEX		
Tropic Turquoise Aguardamarina																No Rodapiés Skirting Board No Tablica Riser	
Bali Zatu Goa					C3											No Rodapiés Skirting Board No Tablica Riser	
Volcanic Lava					C3											No Rodapiés Skirting Board No Tablica Riser	

Collection
Colección

Weights are subject to change

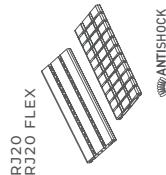
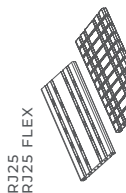
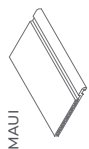

	inches	pieces/box	sem/caja	box/pallet	kg/box	kg/pallet	gross weight	sem/pallet	m ²	kg	m ²	pieces/pallet	pallet size	Crosscut	Venicut	Savoy	Stromboli	Cupra	Salern	Corallina	Lao	Eterna	Iconic	Calacatta	Cemets	Cotto	Amazonia	Tropic	Bali	Volcanic										
MAUI EDGE - Ref. BPMA 0000 33x50	12,7" x 19,7"	2	-	60	13,30	798	-	120	-	-	-	110x95x80		○	○	◆	●	●	●	●	●																			
MAUI EDGE CORNER PACK Ref. BPMA EE00 33x50 / BPMA E100 33x50	-	1 set	-	-	-	-	-	-	-	-	-	-	-	○	○	◆	●	●	●	●	●																			
MAUI CURVED EDGE Ref. BPMA RE00 33x... / BPMA RI00 33x...	-	/radio	-	-	-	-	-	-	-	-	-	-	-	○	○	◆	●	●	●	●	●																			
ARUBA EDGE - Ref. BPAR 0000 25x50	9,6" x 19,7"	2	-	66	11,35	750	-	132	-	-	-	110x95x90		○	○	●	●	●	●	●	●																			
ARUBA EDGE CORNER PACK Ref. BPAR EE00 25x50 / BPAR E100 25x50	-	1 set	-	-	-	-	-	-	-	-	-	-	-	○	○	●	●	●	●	●	●																			
ARUBA CURVED EDGE - Ref. BPAR RE00 25x... / BPAR RI00 25x...	-	/radio	-	-	-	-	-	-	-	-	-	-	-	○	○	●	●	●	●	●	●																			
DRAIN GRATE RJ25 INV - Ref. RJ25 0000 INV 25x50	9,6" x 19,7"	2	-	-	-	-	-	-	-	-	-	110x95x88		○	○	◆	●	●	●	●	●	●	●	●	●	●	●	●	●	●	●	●	●							
DRAIN GRATE RJ25 INV CORNER PACK Ref. RJ25 E000 INV 25x...	-	1 set	-	-	-	-	-	-	-	-	-	-	-	○	○	◆	●	●	●	●	●	●	●	●	●	●	●	●	●	●	●	●	●							
DRAIN GRATE RJ25 - Ref. RJ25 0000 25x50	9,6" x 19,7"	2	-	96	9,60	922	-	192	-	-	-	110x95x90		○	○	●	●	●	●	●	●	●	●	●	●	●	●	●	●	●	●	●	●	●						
DRAIN GRATE RJ25 CORNER PACK Ref. RJ25 E000 25x...	-	1 set	-	-	-	-	-	-	-	-	-	-	-	○	○	●	●	●	●	●	●	●	●	●	●	●	●	●	●	●	●	●	●	●	●					
CURVED DRAIN GRATE RJ25 Ref. RJ25 RE00 25x... / RJ25 RI00 25x...	-	/radio	-	-	-	-	-	-	-	-	-	-	-	○	○	◆	●	●	●	●	●	●	●	●	●	●	●	●	●	●	●	●	●	●	●	●				
DRAIN GRATE RJ25 FLEX - Ref. RJ25 FLEX 25x50	9,6" x 19,7"	2	-	96	9,60	922	-	192	-	-	-	110x105x90		○	○	●	●	●	●	●	●	●	●	●	●	●	●	●	●	●	●	●	●	●	●	●	●			
DRAIN GRATE RJ25 FLEX CORNER PACK Ref. RJ25 E000 FLEX 25x...	-	1 set	-	152	4,20	638	-	152	-	-	-	-	-	○	○	●	●	●	●	●	●	●	●	●	●	●	●	●	●	●	●	●	●	●	●	●	●			
DRAIN GRATE RJ20 - Ref. RJ20 0000 20x50	7,6" x 19,7"	2	-	128	7,80	998	-	256	-	-	-	110x95x92		○	○	◆	●	●	●	●	●	●	●	●	●	●	●	●	●	●	●	●	●	●	●	●	●			
DRAIN GRATE RJ20 CORNER PACK Ref. RJ20 E000 20x...	-	1 set	-	-	-	-	-	-	-	-	-	-	-	○	○	◆	●	●	●	●	●	●	●	●	●	●	●	●	●	●	●	●	●	●	●	●	●			
CURVED DRAIN GRATE RJ20 Ref. RJ20 RE00 20x... / RJ20 RI00 20x...	-	/radio	-	-	-	-	-	-	-	-	-	-	-	○	○	◆	●	●	●	●	●	●	●	●	●	●	●	●	●	●	●	●	●	●	●	●	●	●		
DRAIN GRATE RJ20 FLEX - Ref. RJ20 FLEX 20x50	7,6" x 19,7"	2	-	128	7,80	998	-	256	-	-	-	110x95x90		○	○	●	●	●	●	●	●	●	●	●	●	●	●	●	●	●	●	●	●	●	●	●	●	●	●	
DRAIN GRATE RJ20 FLEX CORNER PACK Ref. RJ20 E000 FLEX 20x...	-	1 set	-	152	3,90	593	-	152	-	-	-	-	-	○	○	●	●	●	●	●	●	●	●	●	●	●	●	●	●	●	●	●	●	●	●	●	●	●	●	
OUTER TRIM - Ref. MDCA E000 4,5x50	1,7" x 19,7"	8	-	-	5,35	-	-	-	-	-	-	-	-	○	○	○	○	○	○	○	○	○	○	○	○	○	○	○	○	○	○	○	○	○	○	○	○	○		
INNER TRIM - Ref. MDCA I000 5,5x50	2,2" x 19,7"	8	-	-	5,35	-	-	-	-	-	-	-	-	○	○	○	○	○	○	○	○	○	○	○	○	○	○	○	○	○	○	○	○	○	○	○	○	○	○	
SCOTH OUTER CORNER - Ref. MDCA EE00 4,5x4,5	1,7" x 17,6"	4	-	-	-	-	-	-	-	-	-	-	-	○	○	○	○	○	○	○	○	○	○	○	○	○	○	○	○	○	○	○	○	○	○	○	○	○	○	
SCOTH INNER CORNER - Ref. MDCA EI00 5,5x5,5	2,2" x 2,2"	4	-	-	-	-	-	-	-	-	-	-	-	○	○	○	○	○	○	○	○	○	○	○	○	○	○	○	○	○	○	○	○	○	○	○	○	○	○	
OUTER ANGLE CORNER - Ref. MDCA AE00 6,5x6,5	2,6" x 2,6"	4	-	-	-	-	-	-	-	-	-	-	-	○	○	○	○	○	○	○	○	○	○	○	○	○	○	○	○	○	○	○	○	○	○	○	○	○	○	
INNER ANGLE CORNER - Ref. MDCA AI00 6,5x6,5	2,6" x 2,6"	4	-	-	-	-	-	-	-	-	-	-	-	○	○	○	○	○	○	○	○	○	○	○	○	○	○	○	○	○	○	○	○	○	○	○	○	○	○	
EXTERNAL TRANSITION CORNER - Ref. MDCA CE00 4,5x25	1,7" x 9,8"	-	-	-	-	-	-	-	-	-	-	-	-	○	○	○	○	○	○	○	○	○	○	○	○	○	○	○	○	○	○	○	○	○	○	○	○	○		
INNER TRANSITION CORNER - Ref. MDCA CI00 5,5x25	2,2" x 9,8"	-	-	-	-	-	-	-	-	-	-	-	-	○	○	○	○	○	○	○	○	○	○	○	○	○	○	○	○	○	○	○	○	○	○	○	○	○	○	
EXTRA COST SPECIAL CURVE - Ref. 6624	-	-	-	-	-	-	-	-	-	-	-	-	-	○	○	○	○	○	○	○	○	○	○	○	○	○	○	○	○	○	○	○	○	○	○	○	○	○	○	
BLOCK 25 SYSTEM - Ref. SISTEMA BLOCK 25 56x20	22" x 7,8"	1	-	60	17	1020	-	60	-	-	-	110x110x13,5		○	○	○	○	○	○	○	○	○	○	○	○	○	○	○	○	○	○	○	○	○	○	○	○	○	○	○
BLOCK EE 25 SYSTEM	-	-	-	-	-	-	-	-	-	-	-	-	-	○	○	○	○	○	○	○	○	○	○	○	○	○	○	○	○	○	○	○	○	○	○	○	○	○	○	
BLOCK EI 25 SYSTEM	-	-	-	-	-	-	-	-	-	-	-	-	-	○	○	○	○	○	○	○	○	○	○	○	○	○	○	○	○	○	○	○	○	○	○	○	○	○	○	○
BLOCK 25 SYSTEM SOLID	-	-	-	-	-	-	-	-	-	-	-	-	-	○	○	○	○	○	○	○	○	○	○	○	○	○	○	○	○	○	○	○	○	○	○	○	○	○	○	○
BLOCK 25 AYATEM HALF SOLID	-	-	-	-	-	-	-	-	-	-	-	-	-	○	○	○	○	○	○	○	○	○	○	○	○	○	○	○	○	○	○	○	○	○	○	○	○	○	○	○

(*) Rectified tiles (♦) No rectified tiles (▼) Cupira: Multi + Marengo (■) Cupira: Hueso + Marengo (●) Cements: Snow (◆) Cupira: Hueso (●) Stromboli: Light + Cream

Colores Disponibles

Available colours



Crosscut Puro Out C3 | In C1



Crosscut Petra Out C3 | In C1



Crosscut Cloud Out C3 | In C1

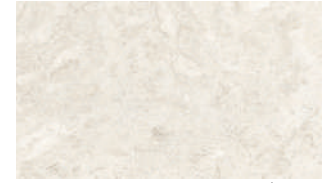

Coralina Aguada Out C3 | In C1



Savoy Moon Out C3 | In C1



Savoy Dessert Out C3 | In C1



Savoy Land Out C3 | In C1



Coralina Samaná Out C3 | In C1



Lao Bone Out C3 | In C1



Lao Sand Out C3 | In C1



Lao Ash Out C3 | In C1



Iconic Stone Out C3 | In C1



Cupira Hueso Out C3 | In C1

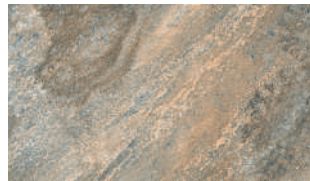

Cupira Multi Out C3

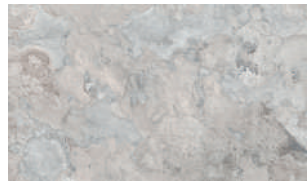

Cupira Marengo Out C3



Calacatta Fresh Out C3 | In C1

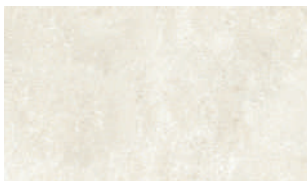

Salem Clar Out C3 | In C1



Salem Dune Out C3 | In C1



Amazonia Miel Out C3 | In C1



Amazonia Canela Out C3 | In C1



Stromboli Light Out C3 | In C1



Stromboli Cream Out C3 | In C1



Stromboli Silver Out C3 | In C1



Cotto Boho Out C3 | In C1



Cements Snow Out C3 | In C1



Cements Warm Out C3 | In C1



Cements Smoke Out C3 | In C1

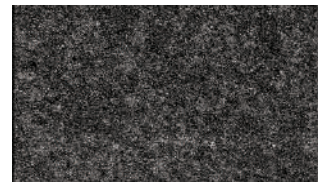

Volcanic Lava Out C3

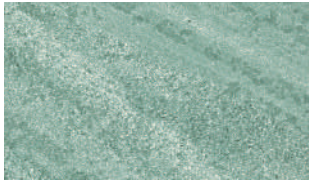

Bali Zatu Out C3

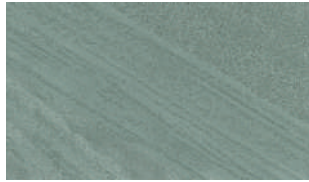

Bali Goa Out C3

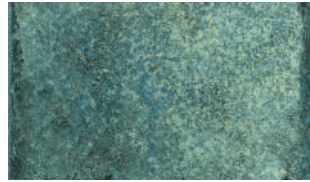

Tropic Turqueta Out C3 | In C1

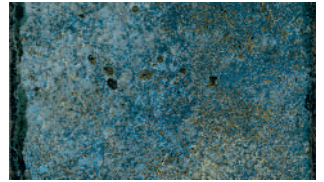

Tropic Aguamarina Out C3 | In C1



Eterna Alba Out C3 | In C1



Eterna Argent Out C3 | In C1

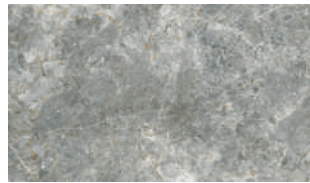

Eterna Cendra Out C3 | In C1



Veincut Arena Out C3 | In C1



Veincut Sahara Out C3 | In C1



Veincut Basalt Out C3 | In C1



CROSSCUT CLOUD



ETERNA CENDRA | ETERNA ALBA

CERÁMICA MAYOR, S.A.

Dirección: Partida Planet, s/n. Callosa d'en Sarrià, Alicante,
España (03510)

Centro logístico: Poligono Industrial Supoi 8, Av. Boverot, 12,
12550 Almassora, Castellón

Teléfono: +34 965 881 175

Web: www.ceramicamayor.com

e-mail: info@ceramicamayor.com



Cerámica Mayor se reserva el derecho de hacer las modificaciones que considere oportunas. Debido a los procesos de impresión, los colores que aparecen en este catálogo deben considerarse aproximados, no exactos.

Toda la información de este catálogo está protegida por copyright. Está prohibida la reproducción total o parcial de los textos, imágenes y representaciones gráficas sin la autorización expresa de Cerámica Mayor.

Los ambientes que se muestran en este catálogo son sugerencias decorativas de carácter publicitario, debiéndose utilizar en la instalación real las instrucciones de colocación de Cerámica Mayor.

